

Amateur Radio Astronomy

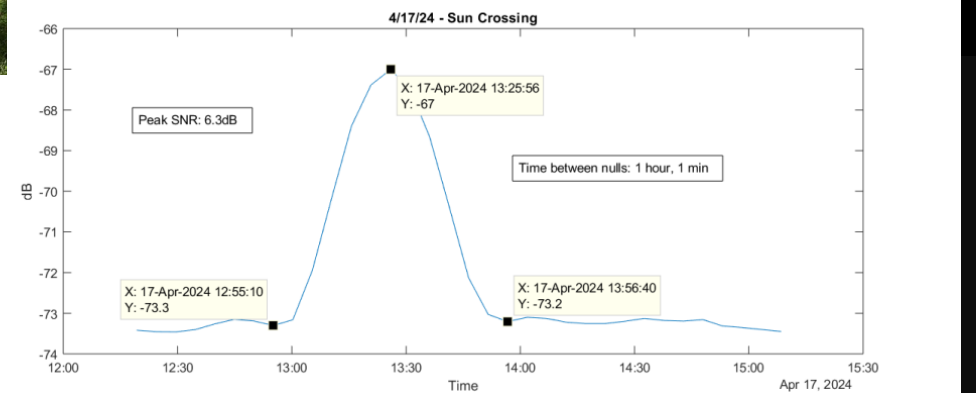
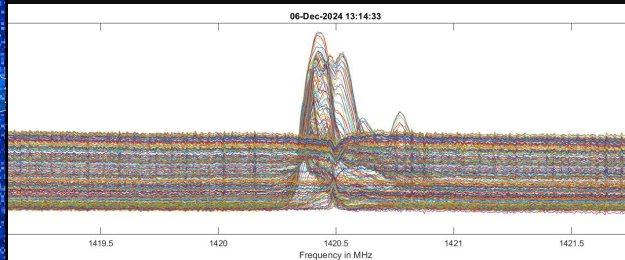
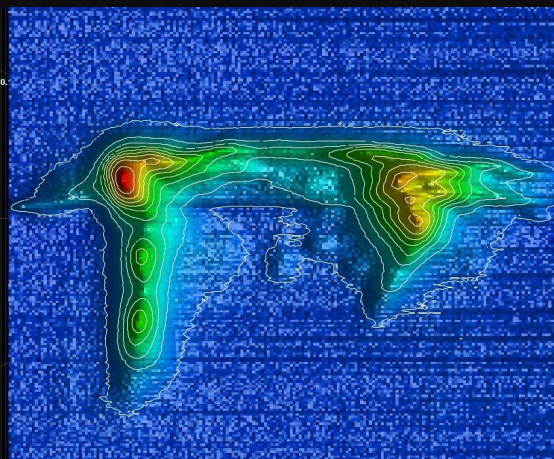
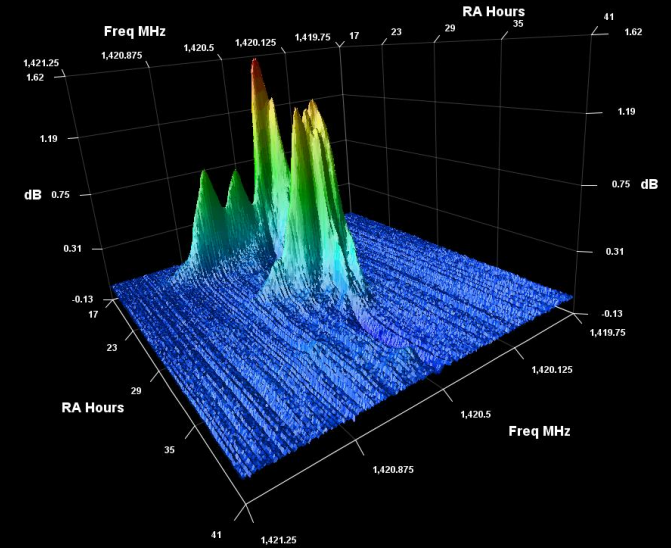
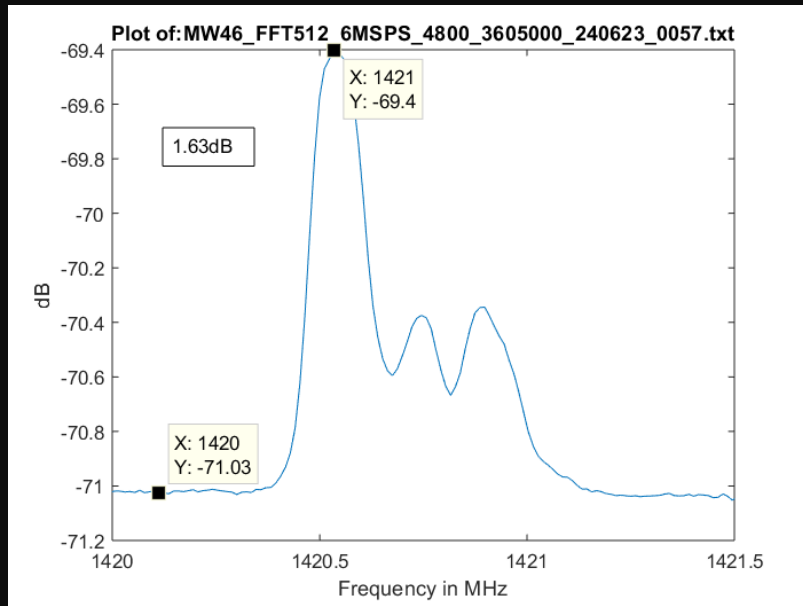

Doug Holland

Who Am I, and Why Am I Standing Up Here Talking to You?

- Member (President) of Johnson Space Center Astronomical Society
- Former NASA Electrical Engineer
 - ❖ Space Shuttle, Space Station, X-38, others
- Current Amateur Astronomer
 - ❖ Astroimaging, Radio Astronomy

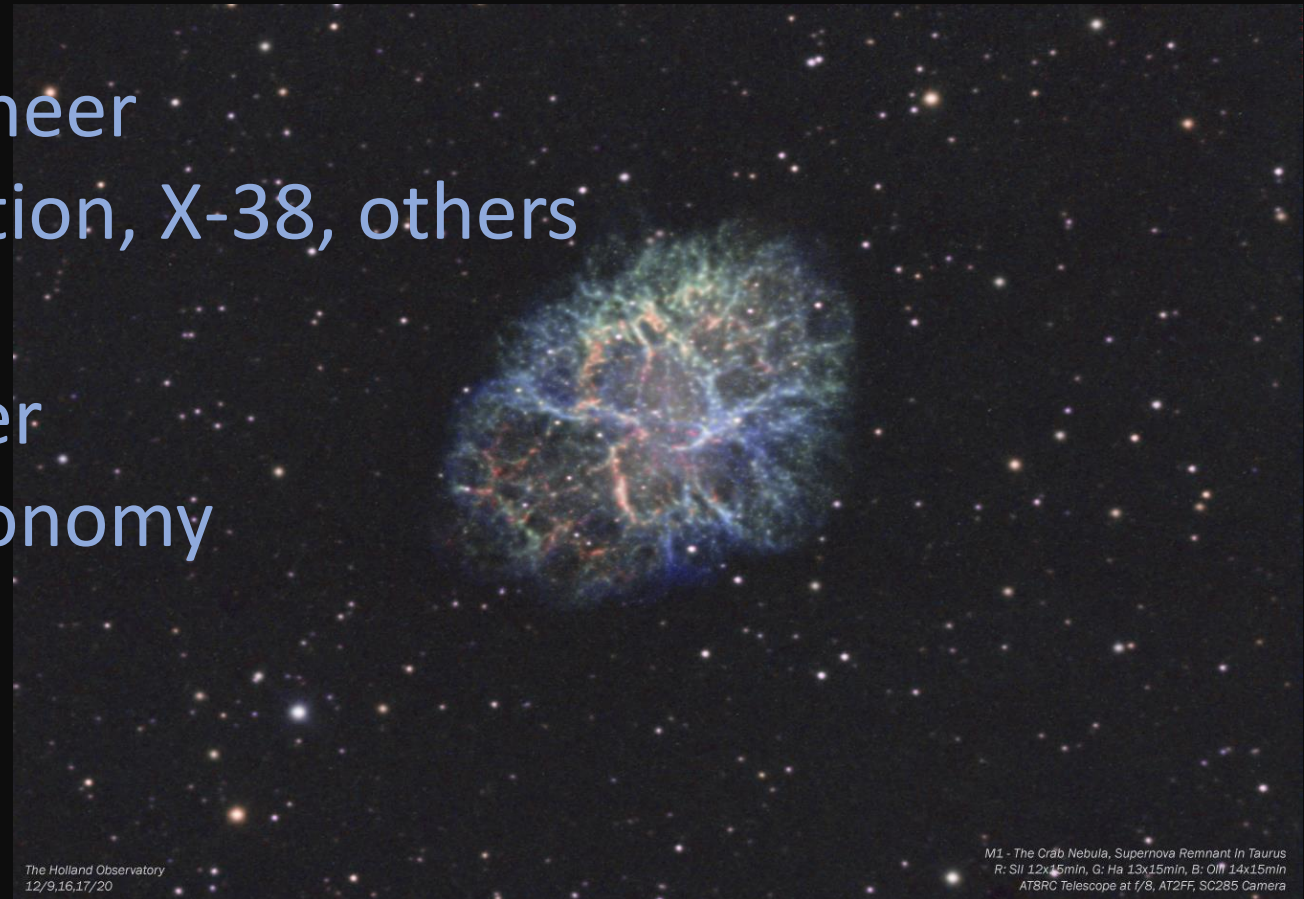

The Holland Observatory
12/9,16,17/20

M1 - The Crab Nebula, Supernova Remnant In Taurus
R: SII 12x15min, G: Ha 13x15min, B: OIII 14x15min
AT8RC Telescope at f/8, AT2FF, SC285 Camera

Doug Holland

Presentation Outline

- General Radio Astronomy Information
- The Architecture of an Amateur Radio Telescope
- Three Configurations Used for this Presentation
- Projects
 - Project 1 – 21cm Neutral Hydrogen with WiFi Antenna
 - Project 2 – Improved 21cm Neutral Hydrogen with 2.1m Antenna
 - Project 3 – Total Power Measurements with 2.1m Antenna
 - Project 4 – What Can be Accomplished with a Satellite TV Dish Antenna
- Other Projects that Can Be Done
- Resources Available for Amateur Radio Astronomy

General Radio Astronomy Information

Why do Radio Astronomy =>

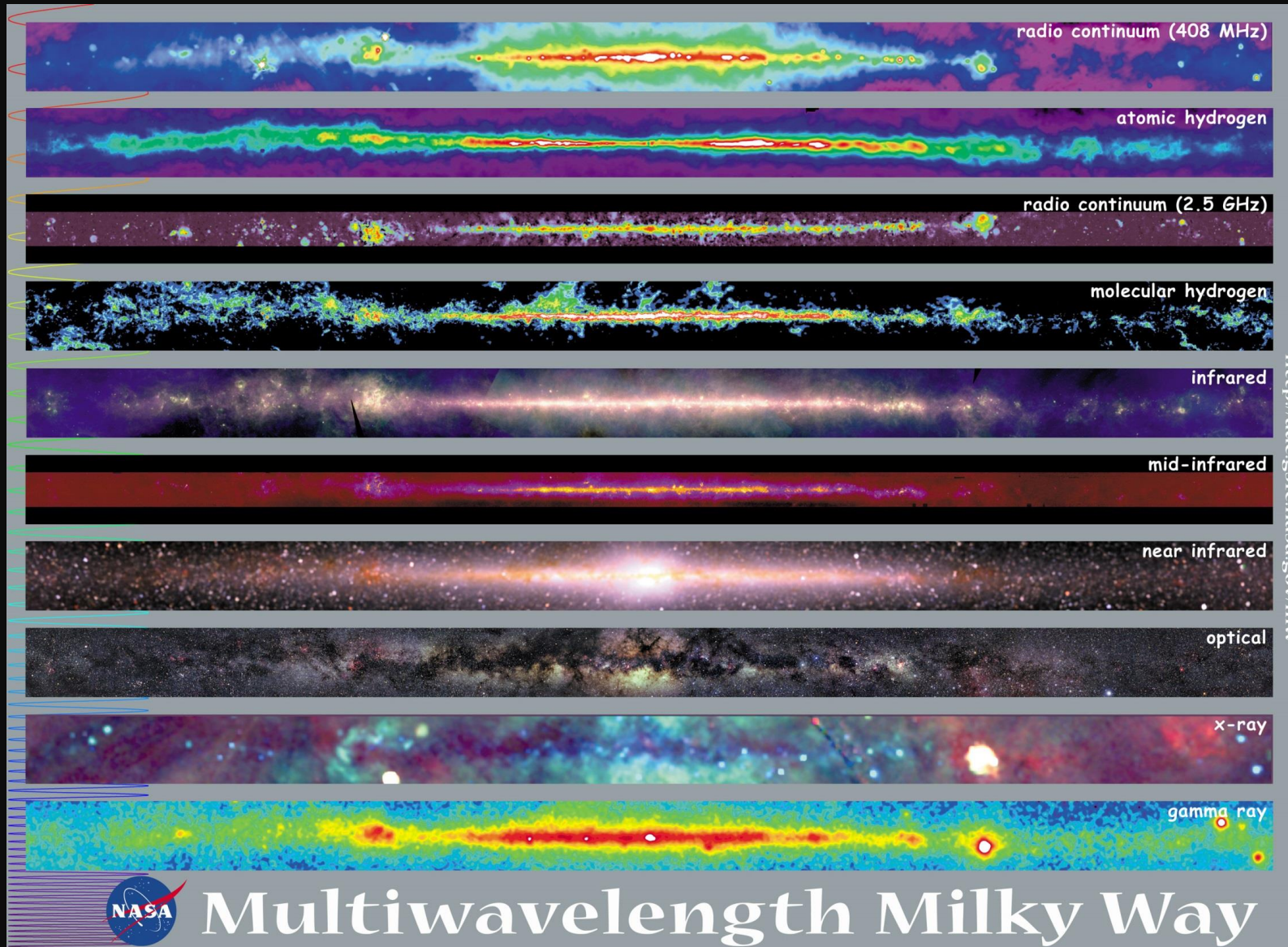

Our galaxy / universe appears very different at different wavelengths

- Physical processes
- Hidden features
- > understanding

<http://adc.gsfc.nasa.gov/mw>

General Radio Astronomy Information (cont'd) Atmospheric Opacity =>

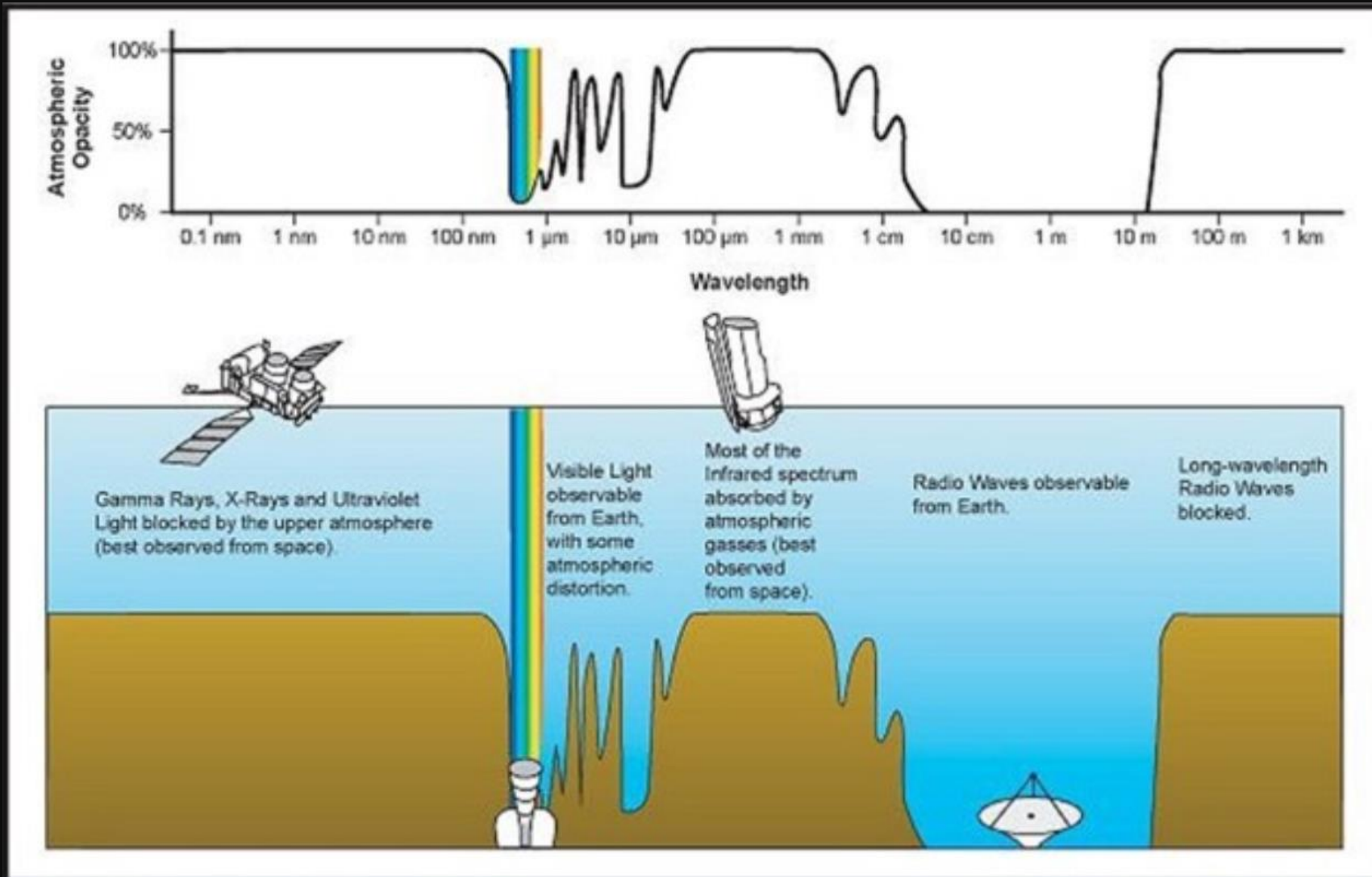

Atmospheric Opacity low for:
Visible Light Wavelengths
Radio Wavelengths

Able to do visible & radio astronomy from the ground

General Radio Astronomy Information (cont'd)

Can be done =>





astroreflect.com



For $\lambda/20$ Error:

At 550nm, approx. 27 nm

* Very difficult to make parabola to 27 nm

At 21cm, approx. 1 cm

* Pretty easy to make parabola to 1 cm

General Radio Astronomy Information (cont'd)

Resolution =>

$$\text{Resolution} \propto \frac{\lambda (\text{wavelength})}{D (\text{diameter})}$$

λ (wavelength)

- Light: 400 to 700nm (10^{-9} m)
- Radio: 1mm (10^{-3} m) to 30m

Resolution

- Visible / Astrophotography : on the order of arcseconds (")
- Radio Astronomy (amateur): on the order of degrees ($^{\circ}$)

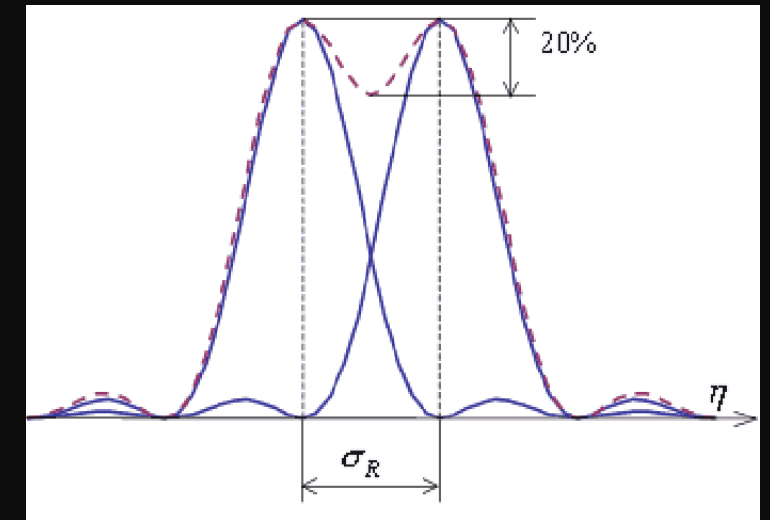

Rayleigh Criteria for resolution
researchgate.net

General Radio Astronomy Information (cont'd)

Large arrays can create high resolution images

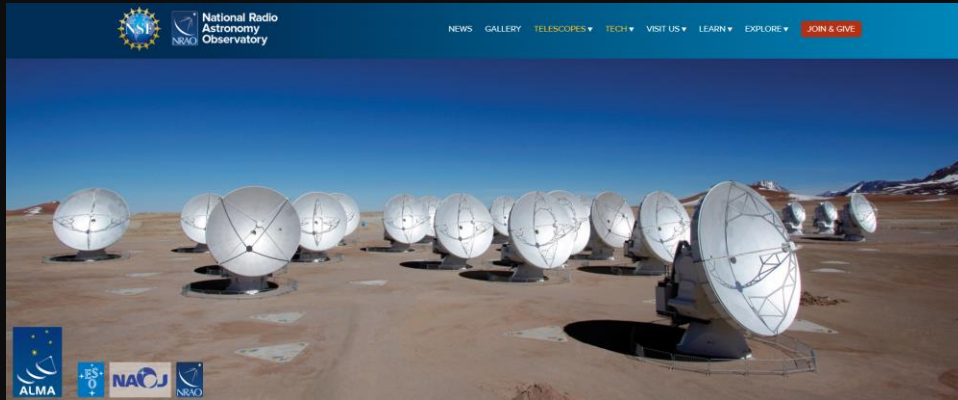

ALMA: Atacama Large Millimeter/submillimeter Array

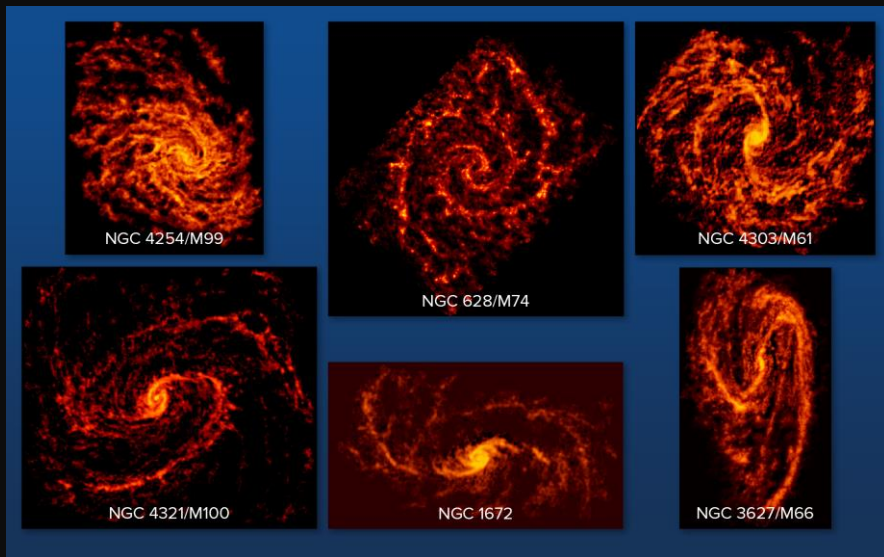

<https://public.nrao.edu/telescopes/alma/science/#galaxies>

Small amateur radio telescopes can 'detect' objects

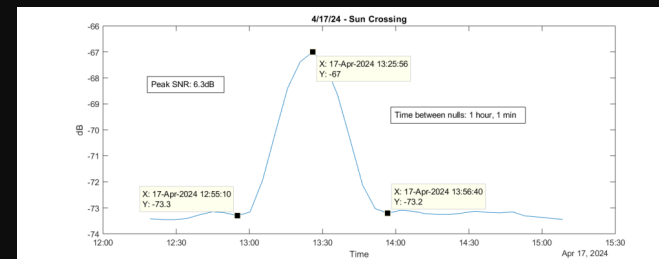

Total power

Doug Holland

Spectrums

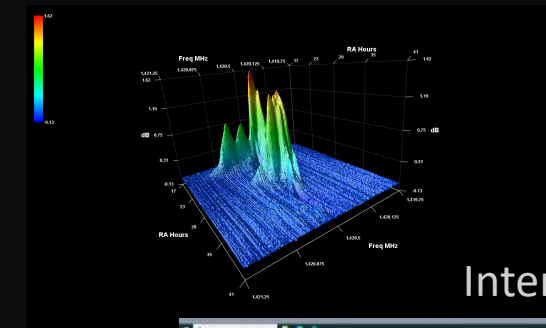
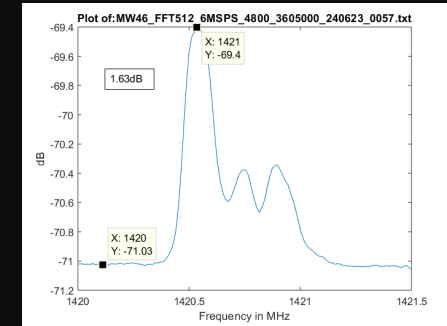

Interferometer

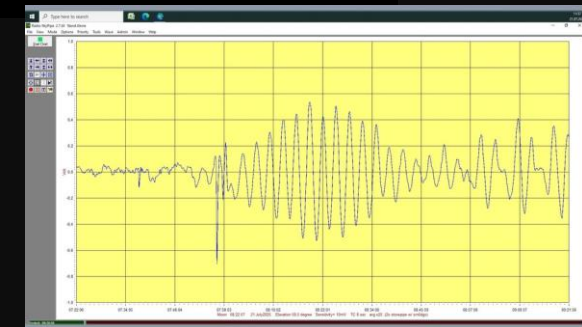

Jan Henning Holmedal Lustrup,
fb Amateur Radio Astronomy

General Radio Astronomy Information (cont'd)

Even though amateur radio astronomers do not generally create high resolution images, there are many exceptional things that can be done =>

- Capture the evidence of the Milky Way's multiple spiral arms
 - Create a model / image of the overall structure of our galaxy
- Measure the rotation rate of our galaxy
- Determine the location of our solar system within the Milky Way
- Measure the changing radio frequency (RF) output of the Sun
- Measure the temperature of the Moon
- Detect:
 - active / radio galaxy
 - star forming region not visible to optical telescopes
 - super nova remnant (SNR)
 - water masers
 - meteors
- Listen to radio emissions from Jupiter
- & a whole lot more

General Radio Astronomy Information (cont'd)

Pointing =>

Most amateur radio telescopes do not track sky

- Line up North / South along local meridian
- Move up and down to set Declination using protractor
- Points at fixed point in the sky, objects cross with Earth rotation



The Architecture of an Amateur Radio Telescope

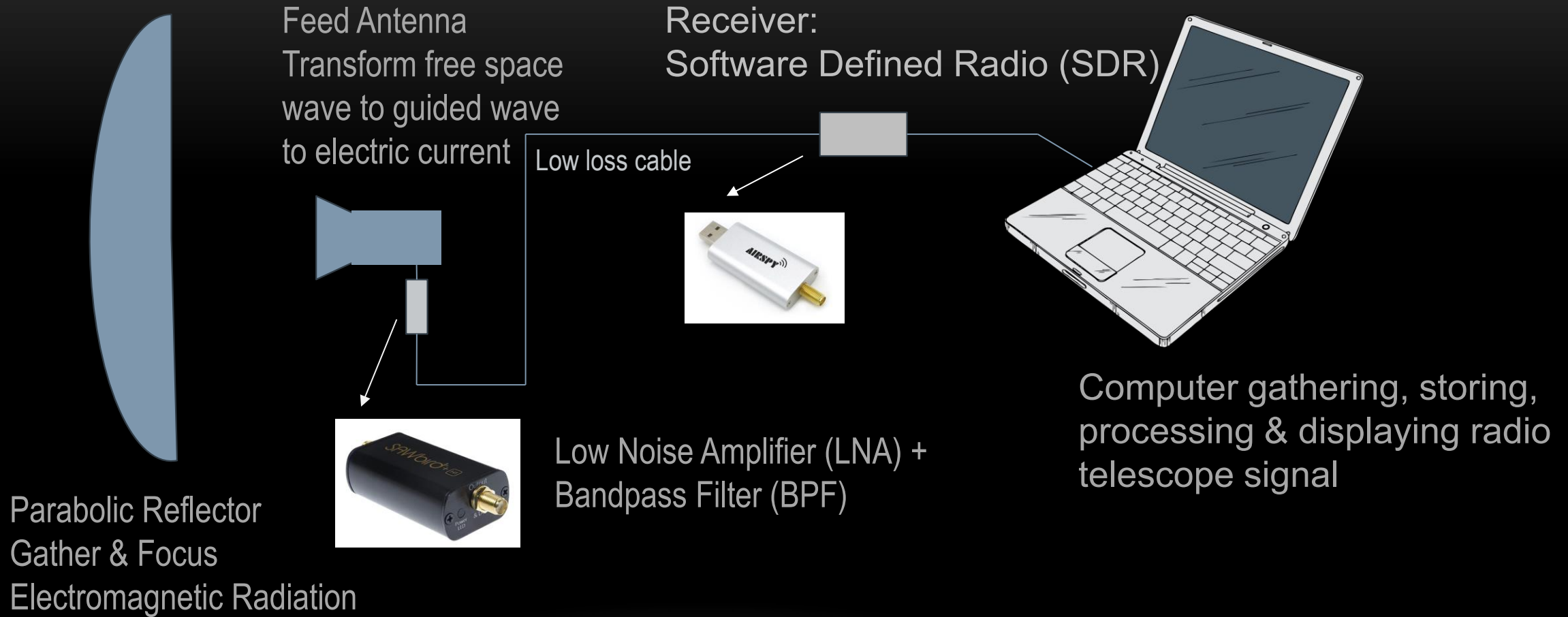

Typical, simplest configuration

Three Configurations Used for this Presentation



Wifi Antenna



2.1m / 7' Radio Telescope



Satellite TV Antenna

Doug Holland

Project 1 – 21cm Neutral Hydrogen with WiFi Antenna

★ Project 1A

Screen Capture Video of Neutral Hydrogen in Milky Way

Project 1 – 21cm Neutral Hydrogen with WiFi Antenna (cont'd)

First, results =>

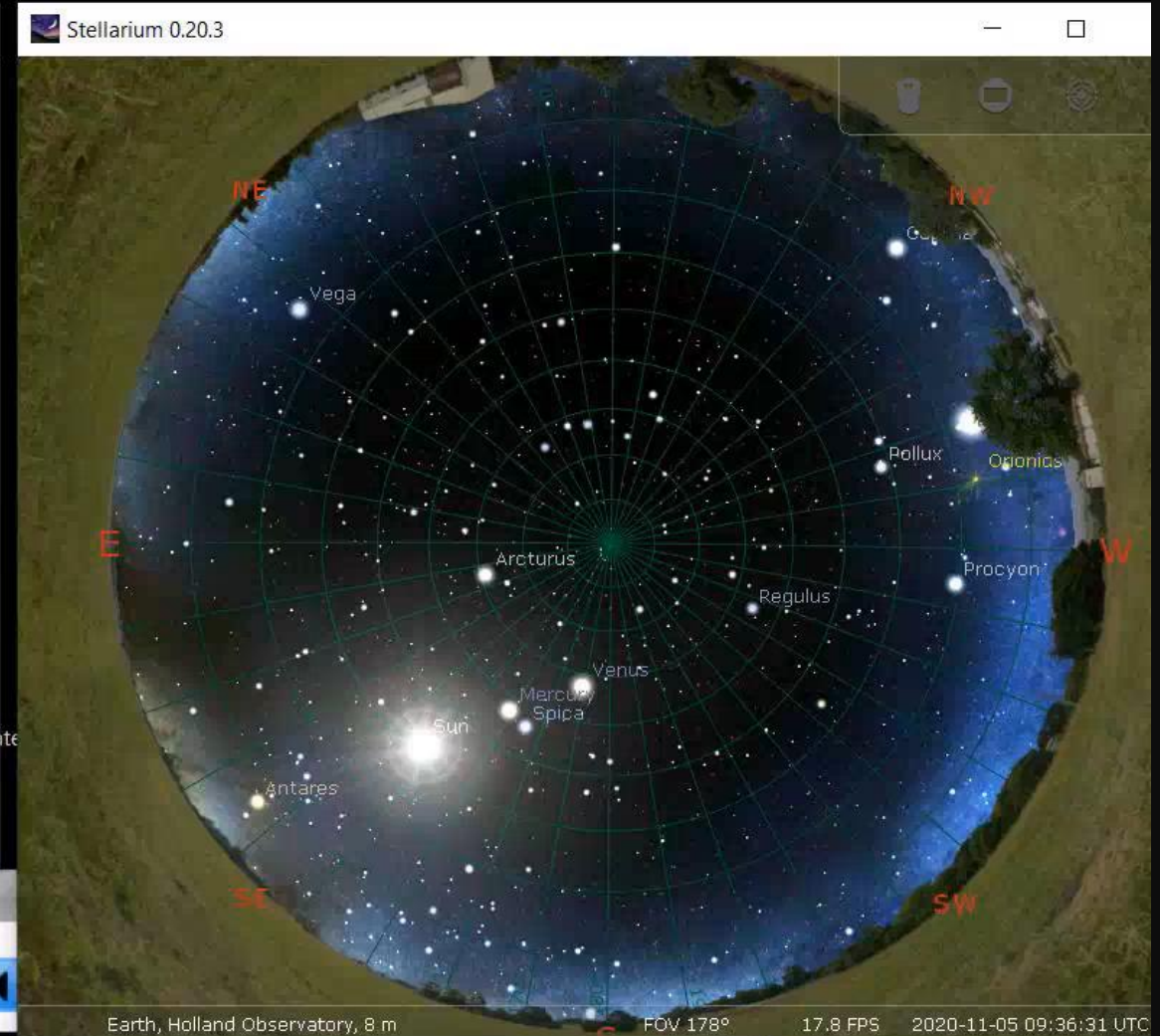

AIRSPY SDR# v1.0.0.1769 - Spy Server Network

001.420.000.000

- IF Noise Blanker *
- Demodulator Noise Blanker *
- Recording *
- Zoom FFT *

2020-11-05 09:36:31.35

The bottom section of the interface shows a control panel with various settings and a zoom FFT plot. The zoom FFT plot shows a signal strength of approximately -70 dBFS at the frequency 001.420.000.000 MHz. The plot is a grid with a vertical line indicating the current frequency.

Project 1 – 21cm Neutral Hydrogen with WiFi Antenna (cont'd)

Why does neutral hydrogen emit at 21cm? =>

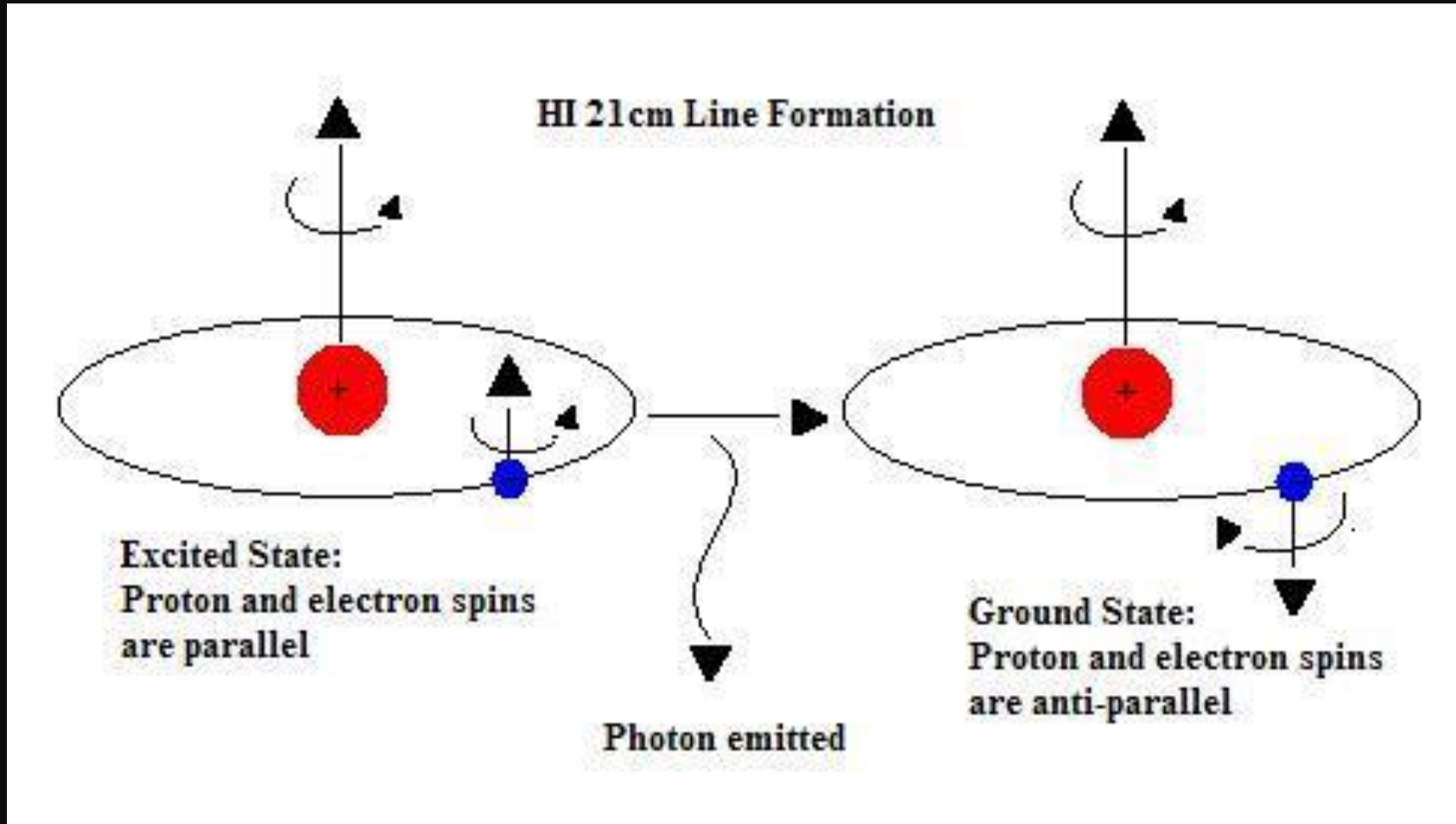

astrobites.org

Doug Holland

Project 1 – 21cm Neutral Hydrogen with WiFi Antenna (cont'd)

How to do =>



21cm Radio Telescope
(21cm => 1.42GHz)
Hydrogen Emission

WiFi Dish Antenna: \$82.99
eBay

- 24dBi gain
- 2.4GHz but works at 1.42GHz
- 14°x10° beam width

Low Noise Amplifier: \$44.95
Amazon

- Nooelec H1 LNA
- 40dB, Designed for 21cm

Software Defined Radio: \$24.95
<https://www.rtl-sdr.com/>
• USB interface, v3

Project 1 – 21cm Neutral Hydrogen with WiFi Antenna (cont'd)

Makes 21cm Neutral Hydrogen
Detection Possible !!



Nooelec SAWbird+ H1 - Premium Saw Filter & Cascaded Ultra-Low Noise Amplifier (LNA) Module for Hydrogen Line (21cm) Applications



This Photo by Unknown Author is licensed under [CC BY-NC](https://creativecommons.org/licenses/by-nc/4.0/)

Project 1 – 21cm Neutral Hydrogen with WiFi Antenna (cont'd)



Software Defined Radio (SDR) interfaces via USB

SDR# software controls SDR (free)

IF Average Plugin used to average multiple samples to decrease noise and increase signal (free)

Stellarium or other planetary program to view Milky Way transit (free)

Chronolaps – screen capture video (free)

Project 1 – 21cm Neutral Hydrogen with WiFi Antenna (cont'd)



Low Noise Amplifier (LNA)

Software Defined Radio (SDR)

Project 1 – 21cm Neutral Hydrogen with WiFi Antenna (cont'd)

[Link to Source of Design](#)

<https://www.rtl-sdr.com/cheap-and-easy-hydrogen-line-radio-astronomy-with-a-rtl-sdr-wifi-parabolic-grid-dish-lna-and-sdrsharp/>

Or – search 'Easy Hydrogen Line Radio Astronomy'

Presentation posted on webpage: www.holland-observatory.net

Project 1 – 21cm Neutral Hydrogen with WiFi Antenna (cont'd)

If you would prefer to buy a kit:



Scope in a Box, \$350

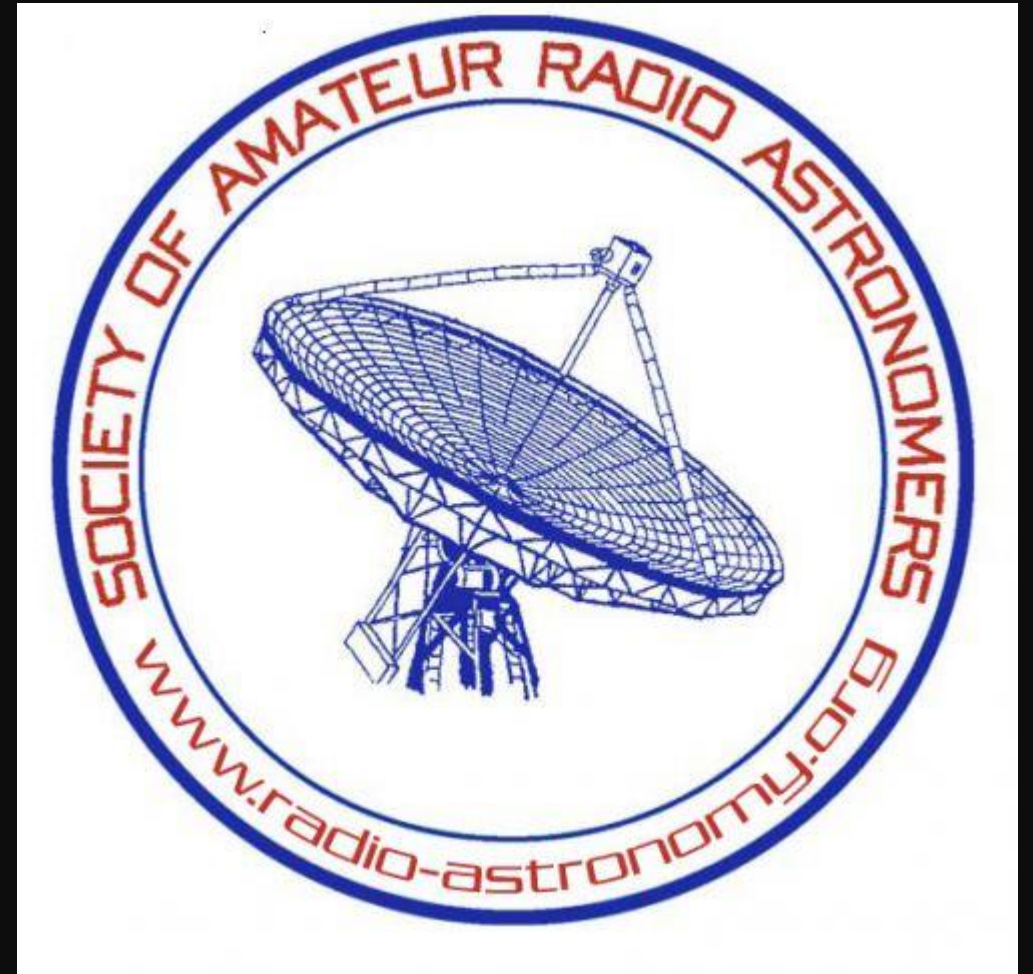

Project 1 – 21cm Neutral Hydrogen with WiFi Antenna (cont'd)

What else can be done with this system?

!!! Measure where our solar system is located within the Milky Way !!!

Solar System Distance from Center of Milky Way

 **Project 1B**

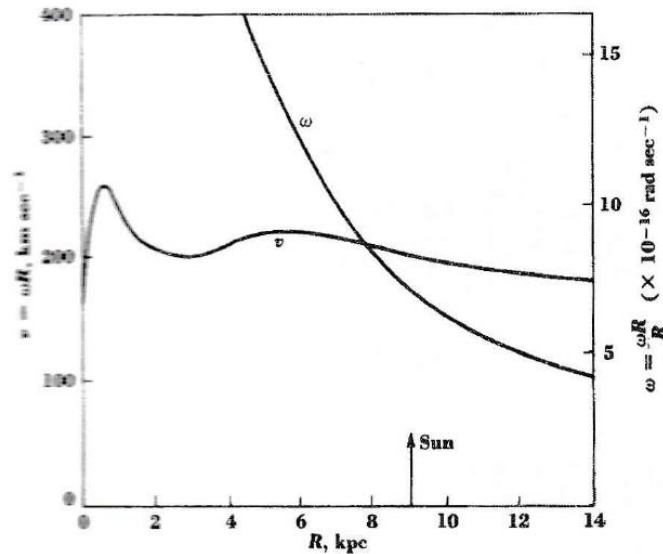
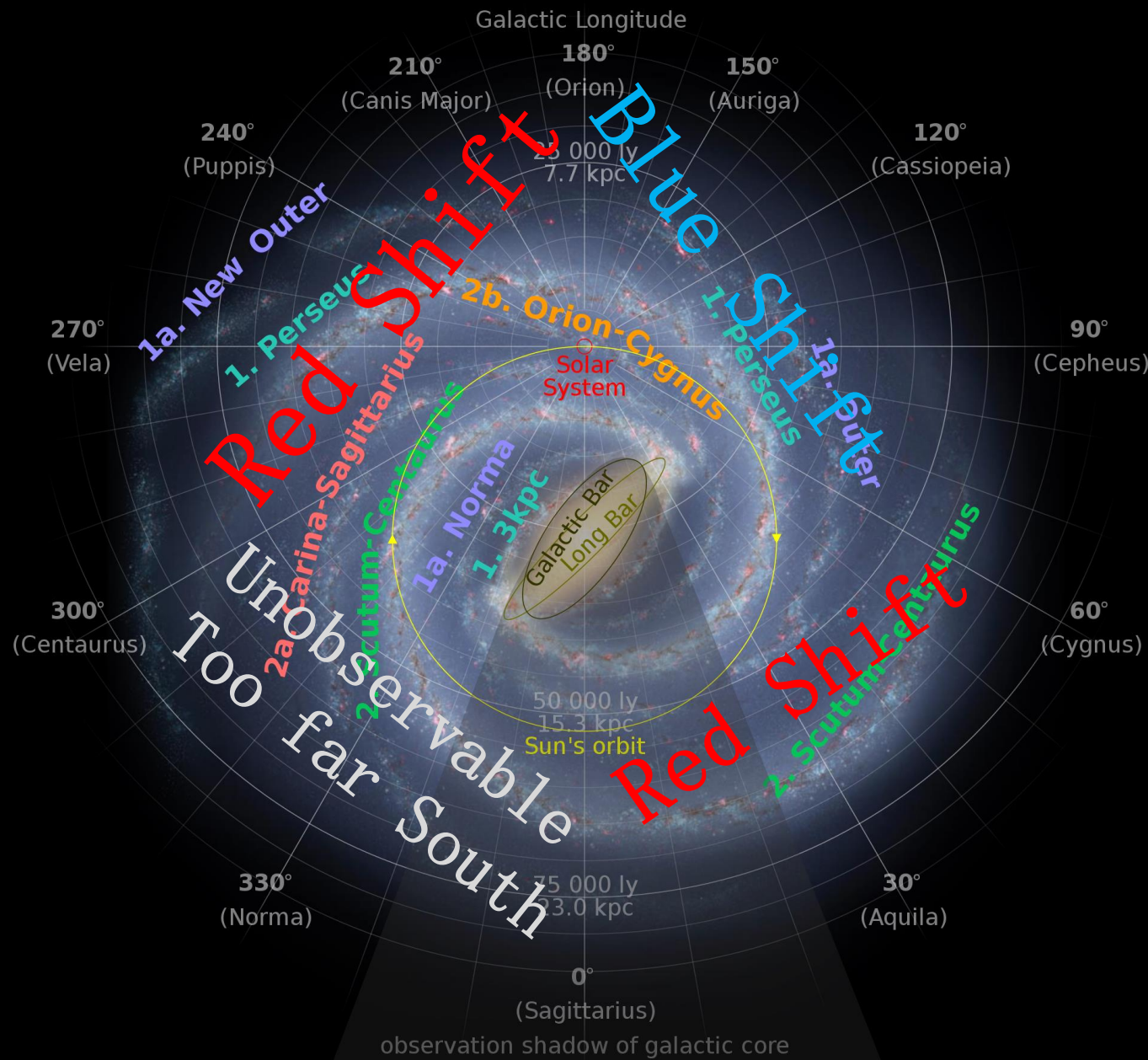

Fig. 8-63. Circular velocity v and angular velocity ω in our galaxy as a function of distance R from the center. (After Rougoor and Oort, 1960.)

Angular velocity (ω) decreases with distance from center of galaxy

Can see intuitively from image of Milky Way. Spiral arms - Closer in areas, higher angular velocity.



21cm Radio Telescope
(21cm => 1.42GHz)
Hydrogen Emission

- WiFi Antenna, Software Defined Radio (SDR)
- Raspberry Pi Configuration

Data gathered along
galactic equator at 10°
increments 11/3 to
11/17, 2020

21cm Plots at Galactic Equator – Spaced at 10 Degrees Declination

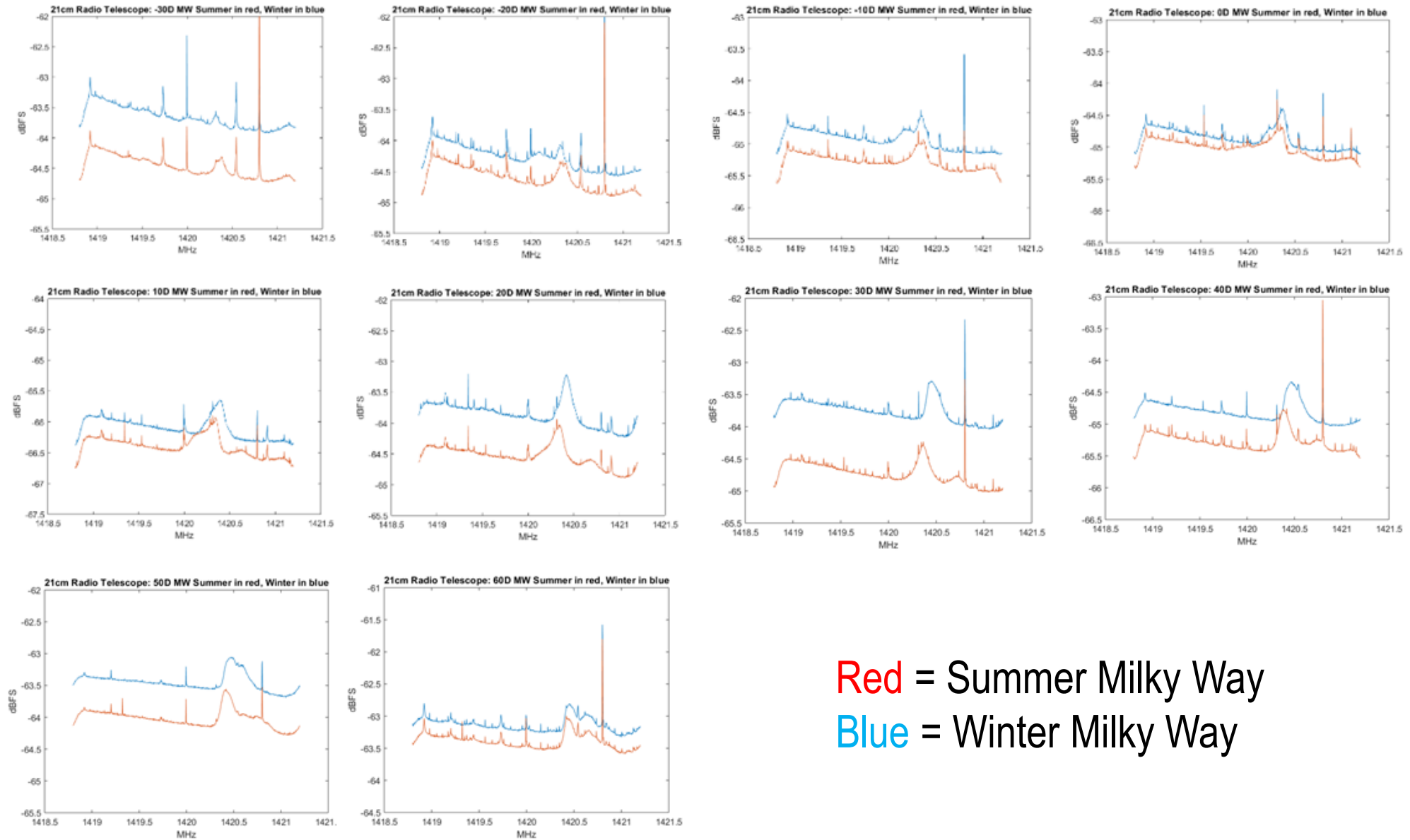

3D Surface Plots of Summer (Red) and Winter (Blue) Milk Way Data

- The **diameter** of the luminous **Milky Way** is between 100,000 and 120,000 light years across.
- Sun (Solar System) is 1/2 to 2/3rds from center (www.universetoday.com)

21cm Radio Telescope: Summer MW DEC -30 to +60 Degrees

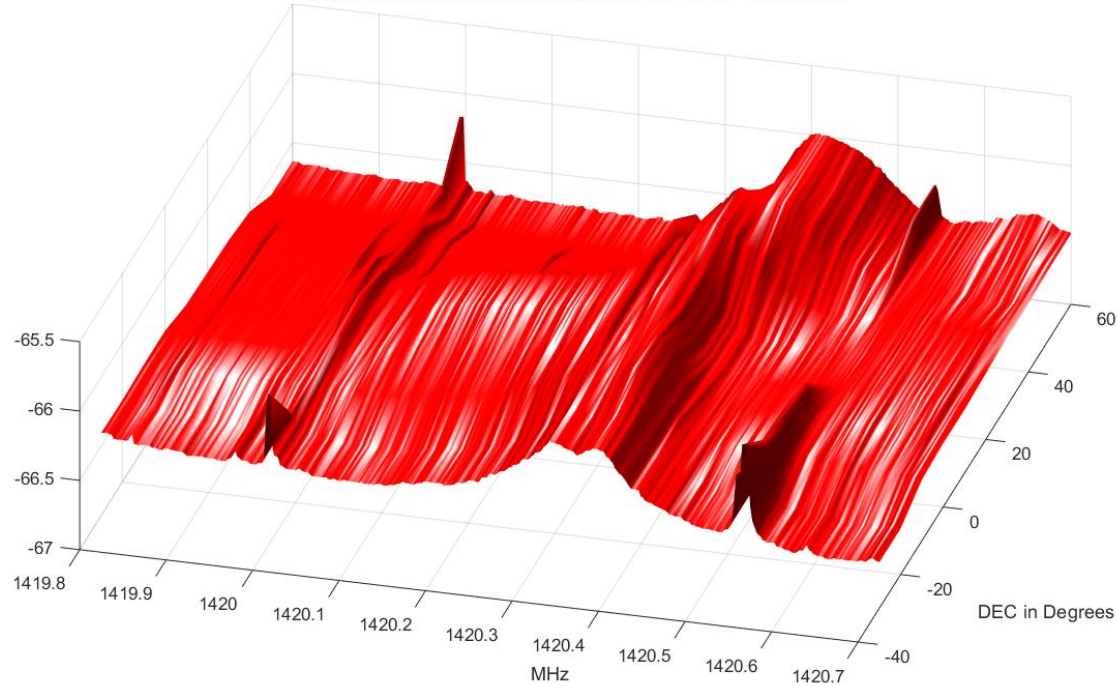

21cm Radio Telescope: Winter MW DEC -30 to +60 Degrees

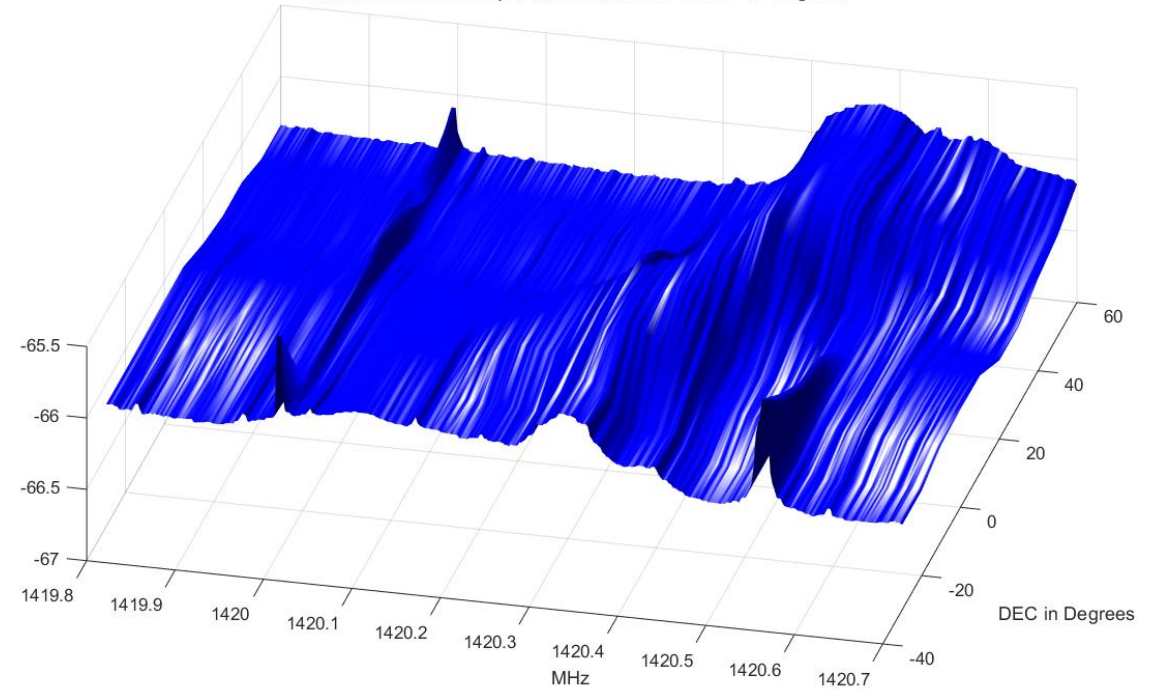

Declination vs. Amplitude vs. Frequency
-30° DEC: Center of galaxy (Sagittarius)
+60° DEC: Most Northerly point of galactic equator (all data taken along galactic equator)

=> Transition between red shift and blue shift is approx. 1/2 to 2/3 from center of galaxy to most Northerly point

Project 2 – Improved 21cm Neutral Hydrogen with 2.1m Antenna

After having some success =>

=> What could we do to improve our results?



Project 2 – Improved 21cm Neutral Hydrogen with 2.1m Antenna (cont'd)

Obviously, make it BIGGER =>



2.1m / 7' Parabolic Dish
f/0.4
Resolution $\approx 7^\circ$ (HPBW)
6mm spaced hardware cloth
Collected flux \propto Dish Area
Doug Holland



Project 2 – Improved 21cm Neutral Hydrogen with 2.1m Antenna (cont'd)

Note – Wifi Antenna came with built in feed antenna
=> Now we need to design and build a feed antenna

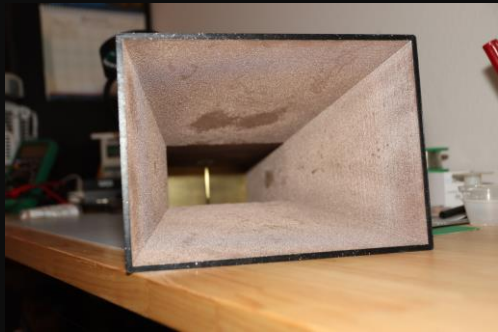

3D Printed Pyramidal Horn



Helical Beam Antenna



Circular Waveguide Horn Antenna



Loop Antenna



Doug Holland



End Result –
Circular Waveguide Horn Best
(aka Cantenna, Stove Pipe Antenna)
* Many online examples

Project 2 – Improved 21cm Neutral Hydrogen with 2.1m Antenna (cont'd)

Things to know about feed antennas 1 =>



You may think that focus is at $\frac{1}{4}$ wave antenna

BUZZ - Wrong – It is near the aperture of the Circular Waveguide (CWG) Antenna

*** Also – just to confuse everyone, the radio astronomers call focus point the 'phase center'

*** Depth of focus is wavelength dependent – more relaxed at radio wavelengths

Doug Holland



Project 2 – Improved 21cm Neutral Hydrogen with 2.1m Antenna (cont'd)

Things to know about feed antennas 2 =>

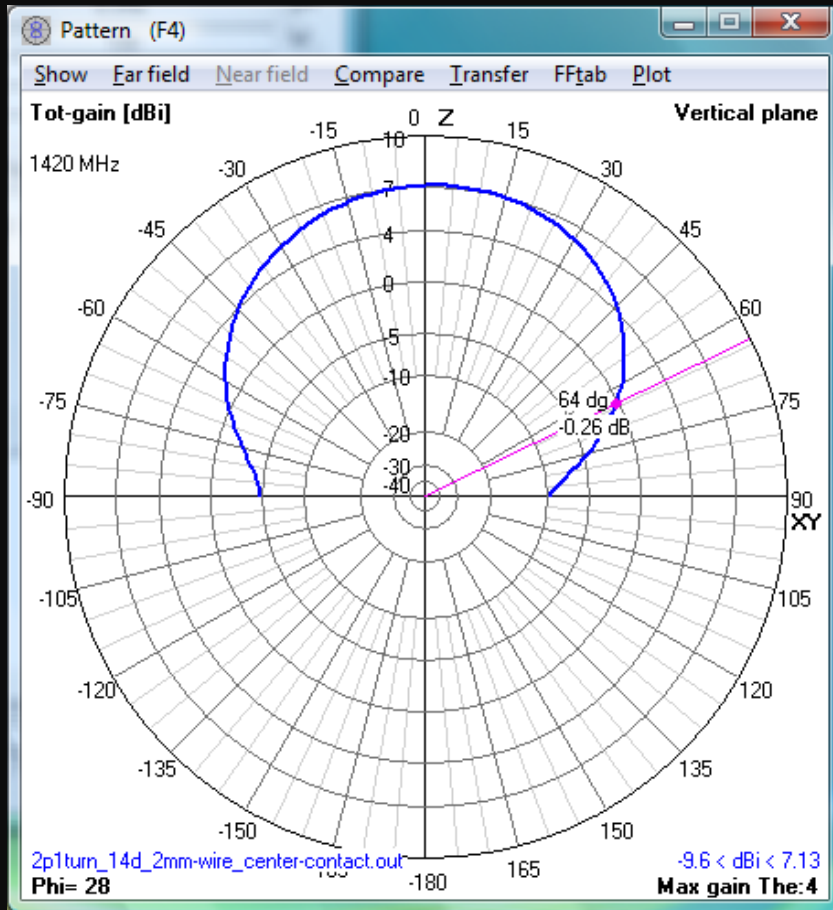

4NEC2 Software

Parabolic Dish

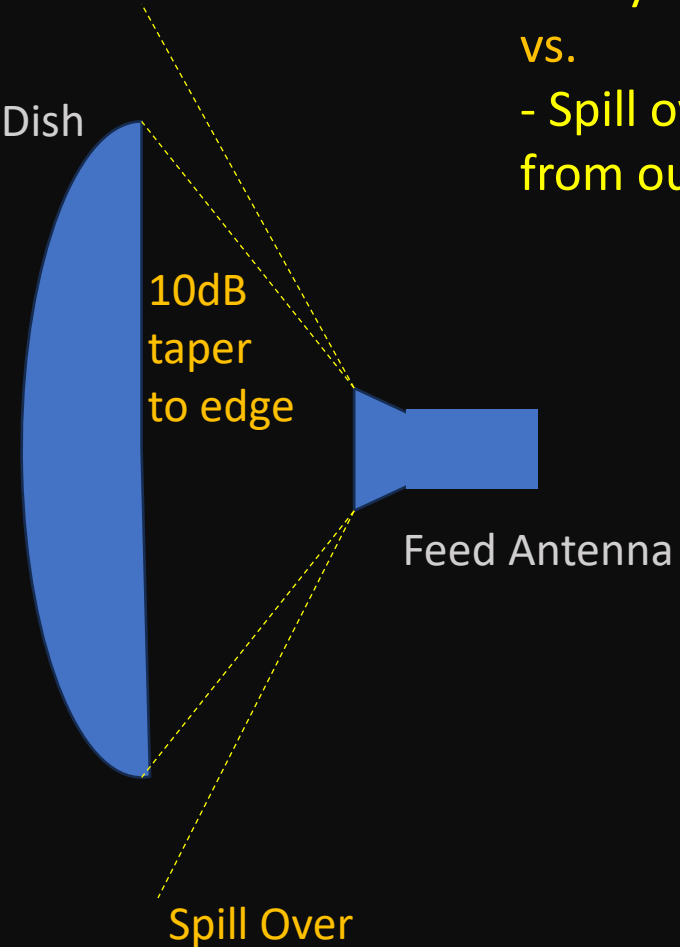

Trade-off

- Fully illuminated dish
- vs.
- Spill over (signal from outside dish)

Doug Holland

Project 2 – Improved 21cm Neutral Hydrogen with 2.1m Antenna (cont'd)

Things to know about feed antennas 3 =>

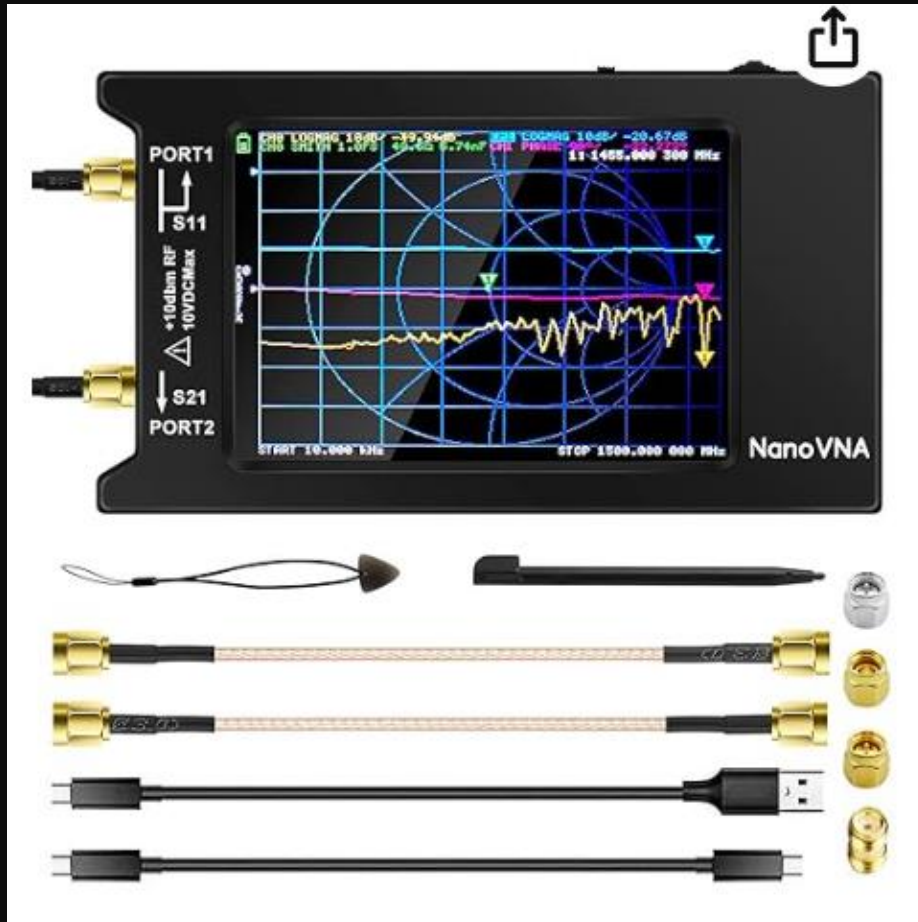

NanoVNA-H4 (Vector Network Analyzer) – very useful for testing feed antennas [\$68 on Amazon]

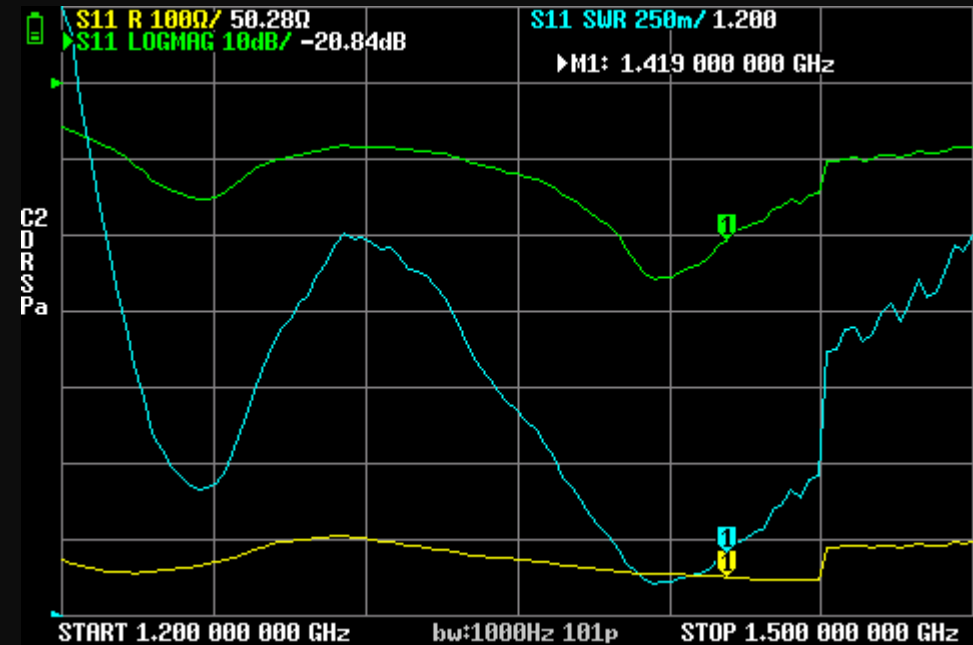

Project 2 – Improved 21cm Neutral Hydrogen with 2.1m Antenna (cont'd)

Things to know about feed antennas 4 =>

Low Noise Amplifier (LNA) is mounted directly on feed antenna

Otherwise, LNA will amplify noise from cabling



Project 2 – Improved 21cm Neutral Hydrogen with 2.1m Antenna (cont'd)

Did we improve our results?

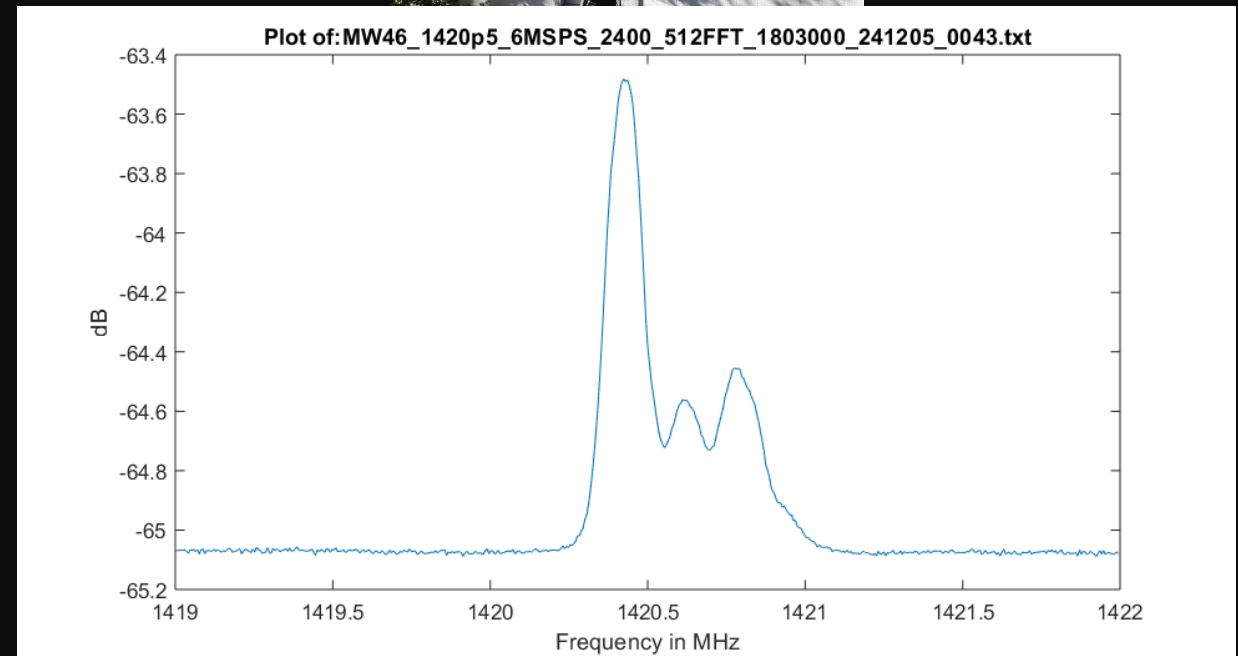
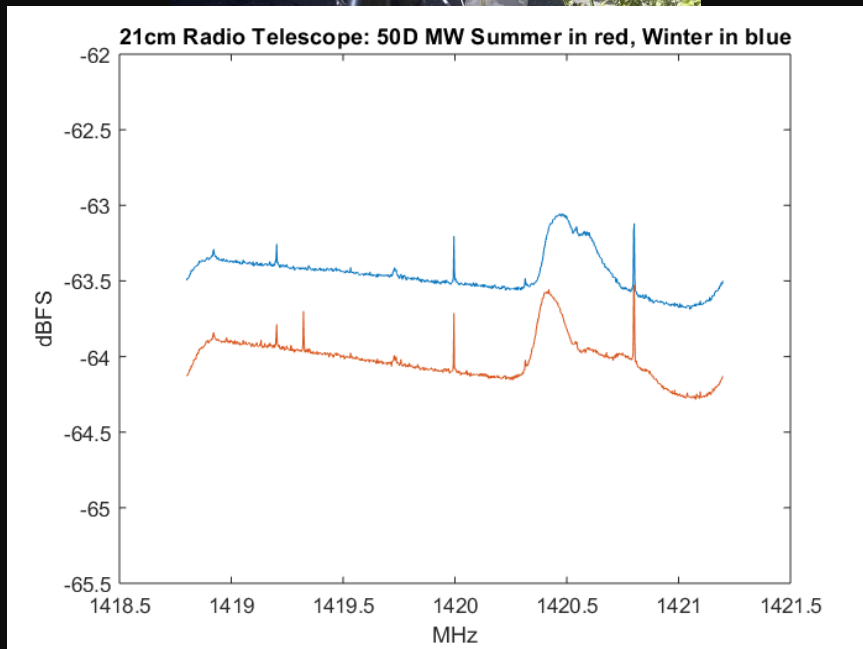

Project 2 – Improved 21cm Neutral Hydrogen with 2.1m Antenna (cont'd)

What can we do with our improved data =>

★ **Project 2A**

Evidence of Multiple Spiral Arms in Milky Way

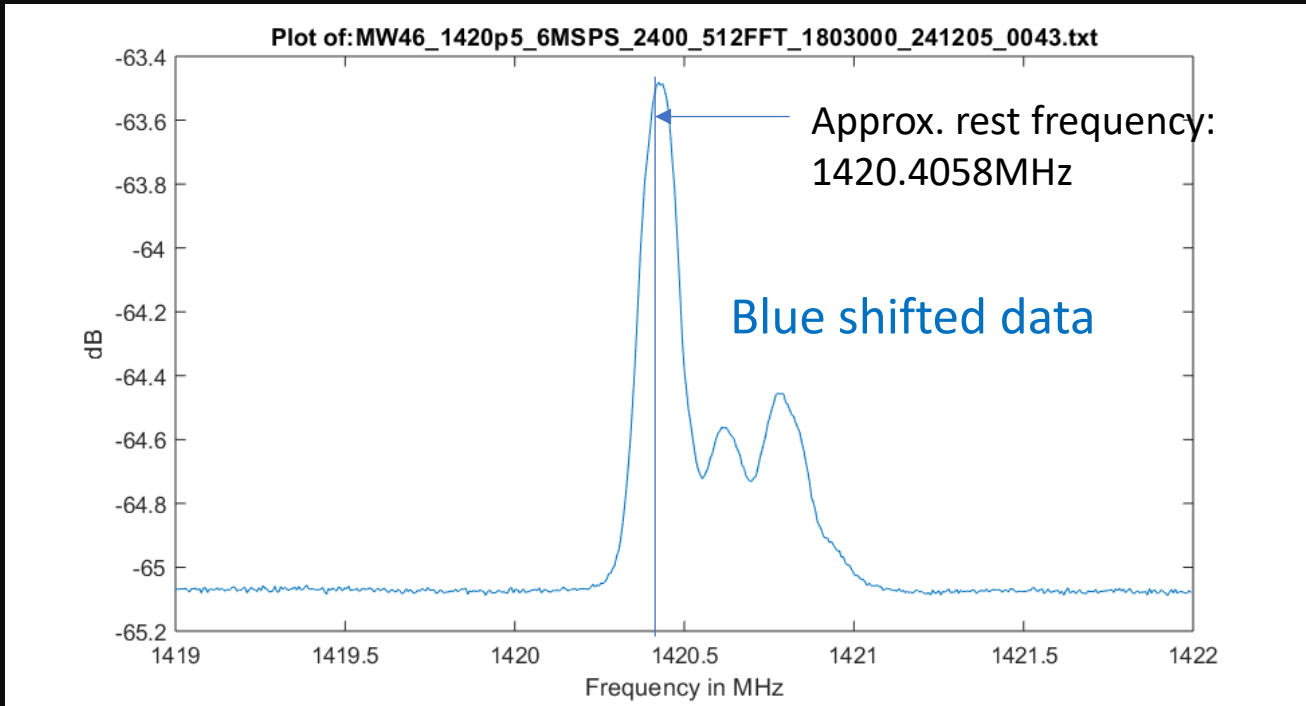

- Neutral Hydrogen rest frequency = 1420.4058MHz
- Blue shift humps are evidence of the Milky Way having multiple spiral arms

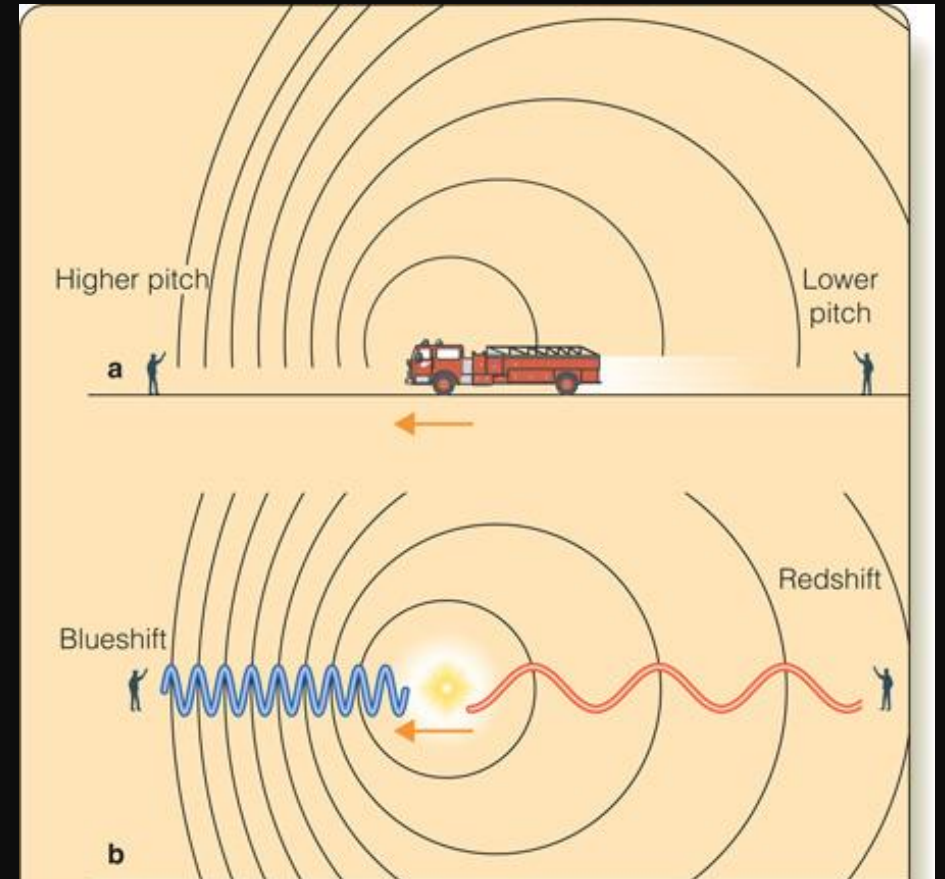

The Doppler Effect

From: Fundamentals of Astronomy, Seeds & Backman

Project 2 – Improved 21cm Neutral Hydrogen with 2.1m Antenna (cont'd)

“Observations of the 21-cm hydrogen line have enabled radio astronomers to deduce for the first time a picture of the spiral structure of our galaxy” Radio Astronomy by John D. Kraus

How can we correlate our data to existing models of our galaxy?

MOTION OF EARTH AND SUN AROUND THE MILKY WAY

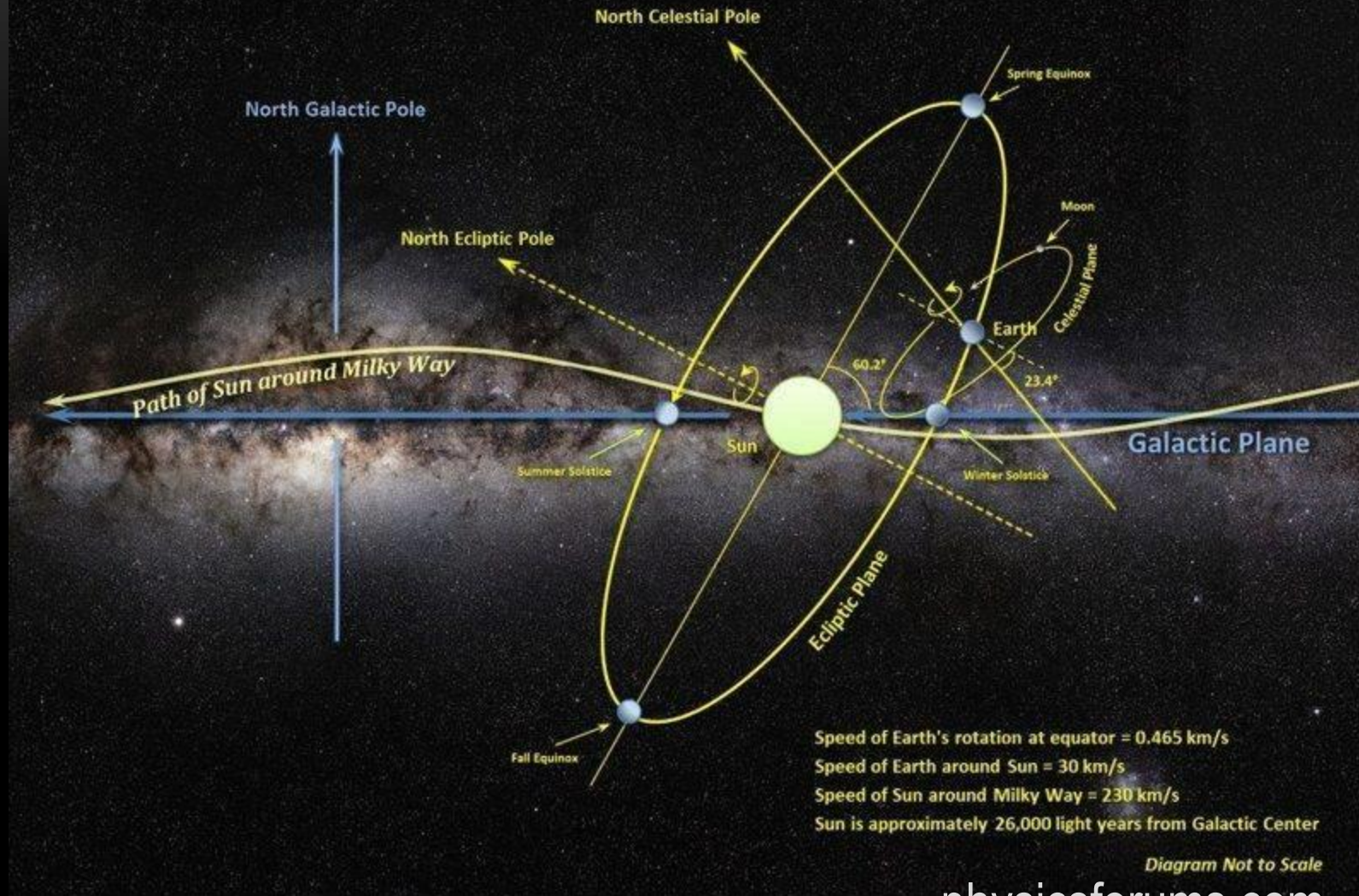

physicsforums.com

What direction are we pointing?

Radio Telescope beam at 47.5 degrees

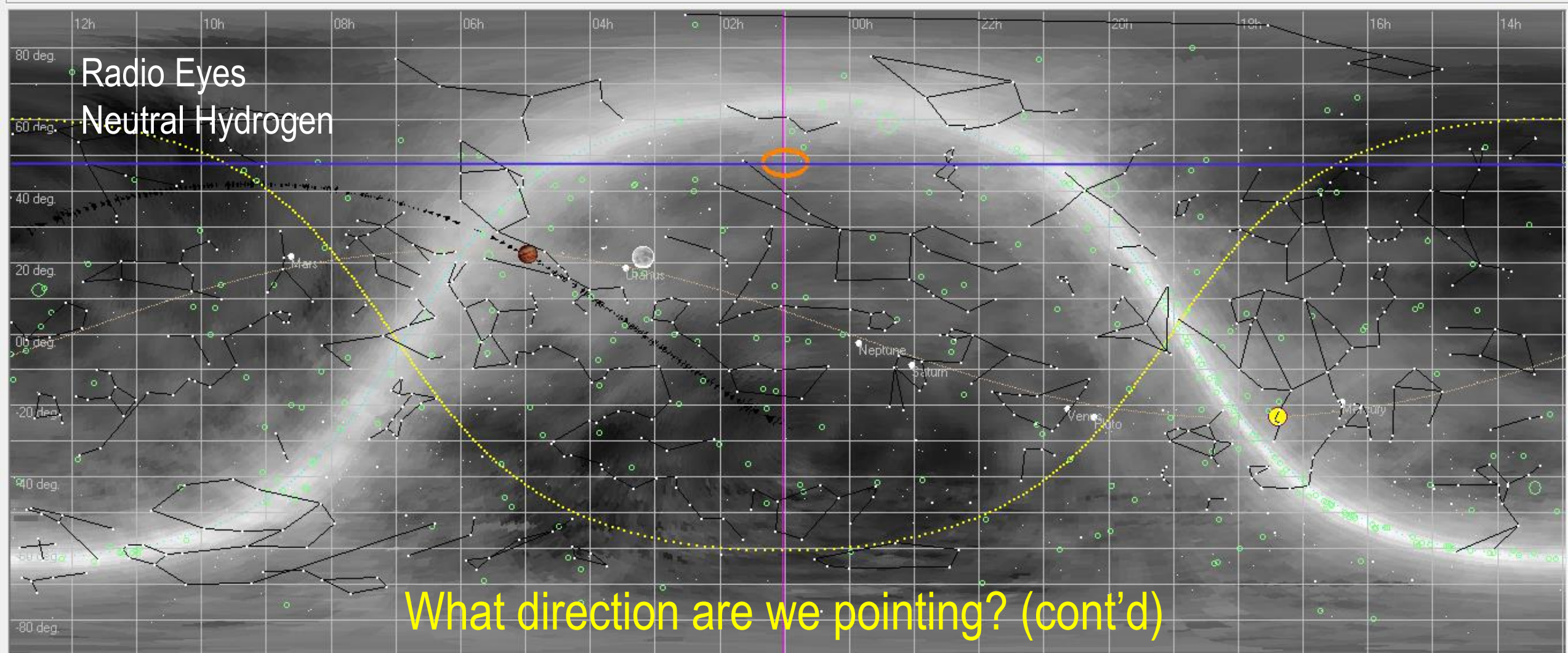

Radio Eyes
Neutral Hydrogen

What direction are we pointing? (cont'd)

Reference - Beam

RA	Declination	Elevation	Azimuth	LMST
00:59:38	47:59:11	71:36:35	358:34:11	01:02:20

Gal Lat	Gal Lng
24.75	121.66

Sources: srcii.dat
Background: neutRH_Gray.gif

298 Radio Objects.

Approximate directions

pablocarlosbudassi.com

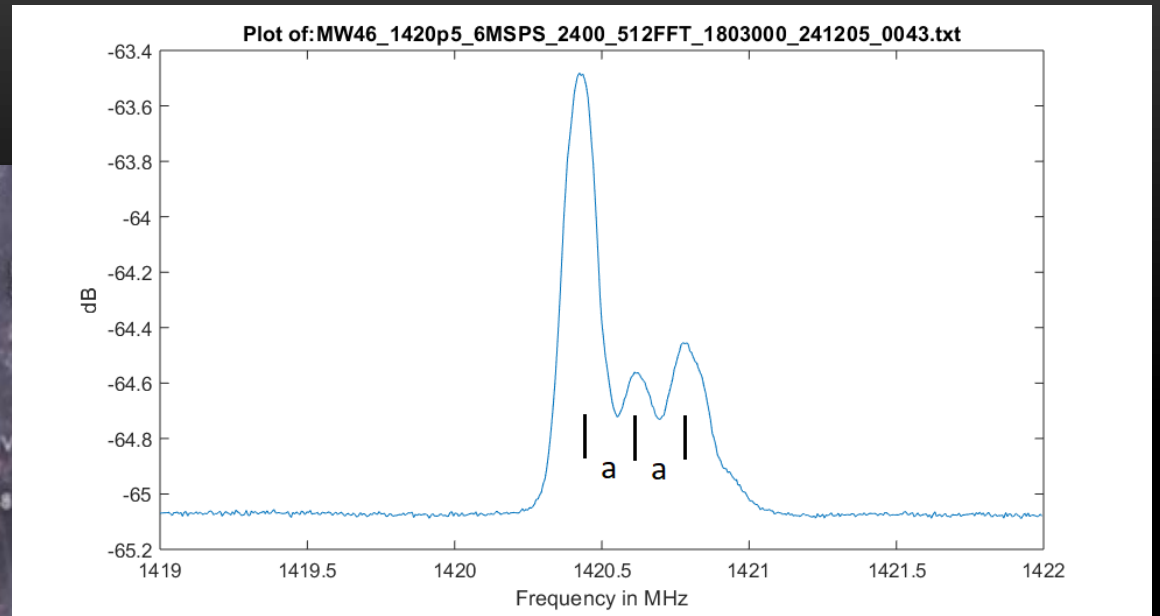

Blue shifted data => approaching

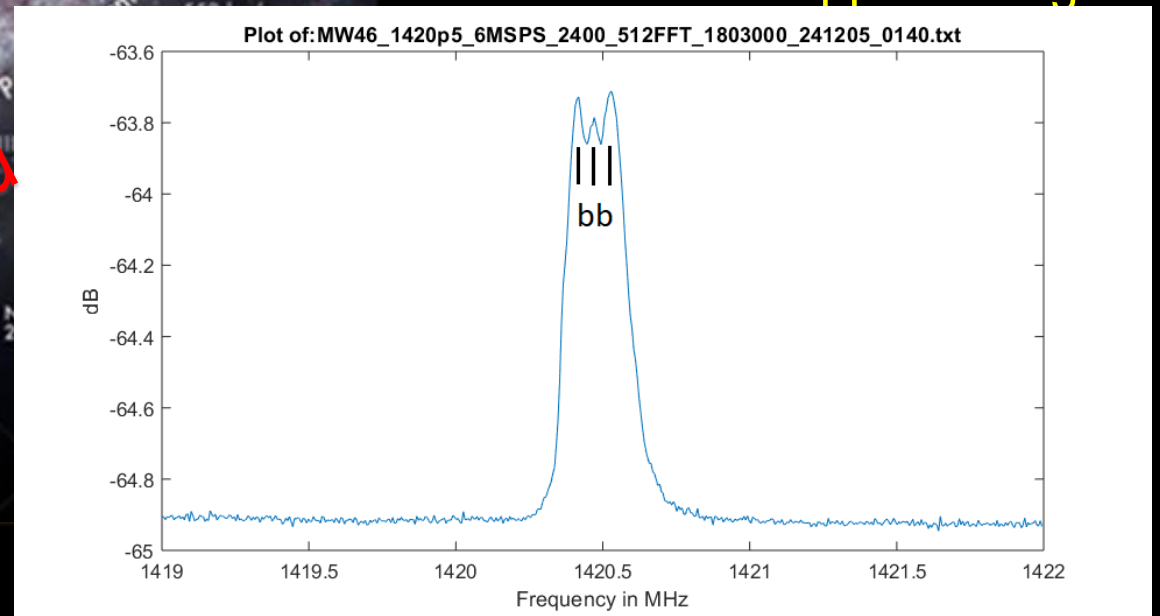

Measured data correlates to accepted models of our galaxy

Project 2 – Improved 21cm Neutral Hydrogen with 2.1m Antenna (cont'd)

★ **Project 2B**

Creating 3D Representation of Our 21cm Neutral Hydrogen Data



Configuration Used for Data

- 2.1m f/0.4 Dish Reflector
- 1420MHz Cylindrical Waveguide Horn
 - With 6 to 7" flared aperture
 - SWR: 1.19
- Noelec H1 LNA
- Airspy Mini Software Defined Radio (SDR)
- Very short USB cable (4 inches)
- Local laptop running SDR# software with IF_Average plugin

New Radio Astronomy Software

- Facebook 'Amateur Radio Astronomy' group
- IFAvg2CSV (free)
 - ❑ Takes files made by SDR# and converts to CSV (CSV – comma separated values)
- Rinearn Graphics (free)
 - ❑ Takes CSV files and plots: 2D and 3D versions

➤ IFAvg2CSV

☐ Takes files made by SDR# and converts to CSV

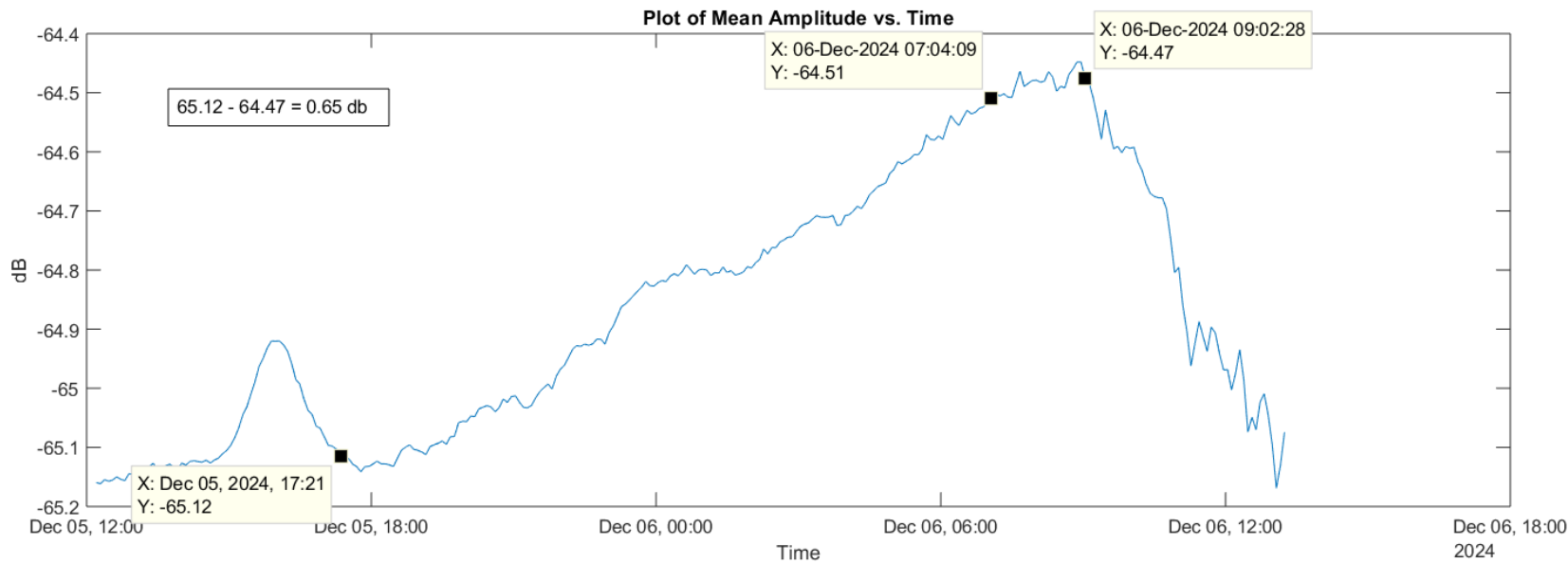

24 hours
DEC 47.5°

Normalizes
Data (original
data has gain
/ baseline
drift)

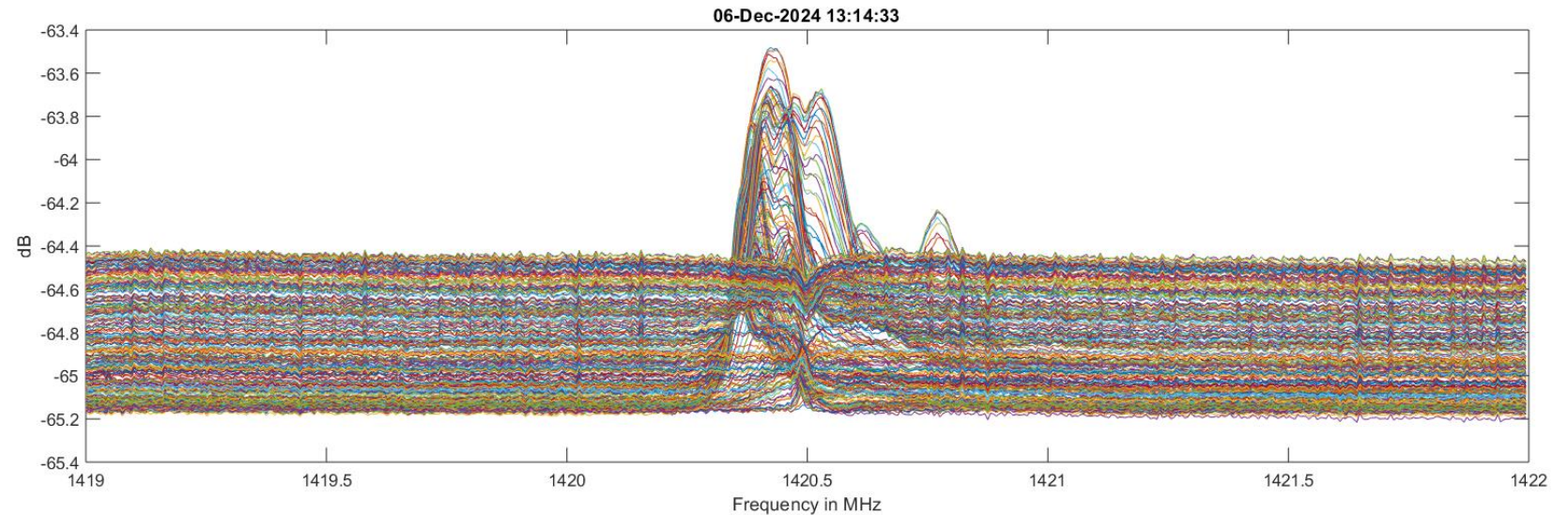

➤ Rinearn Graphics

☐ Takes CSV files and plots: 2D and 3D versions

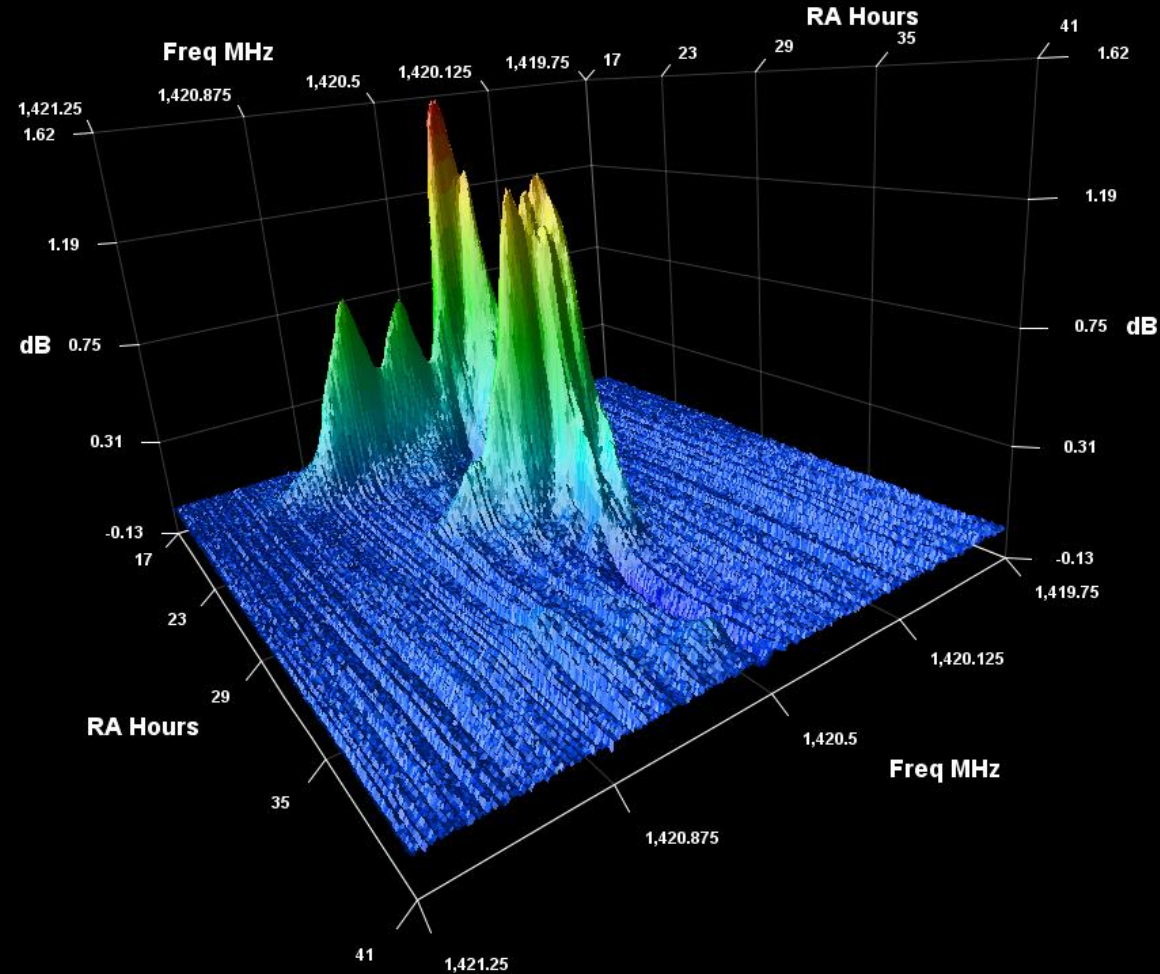
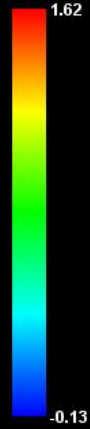

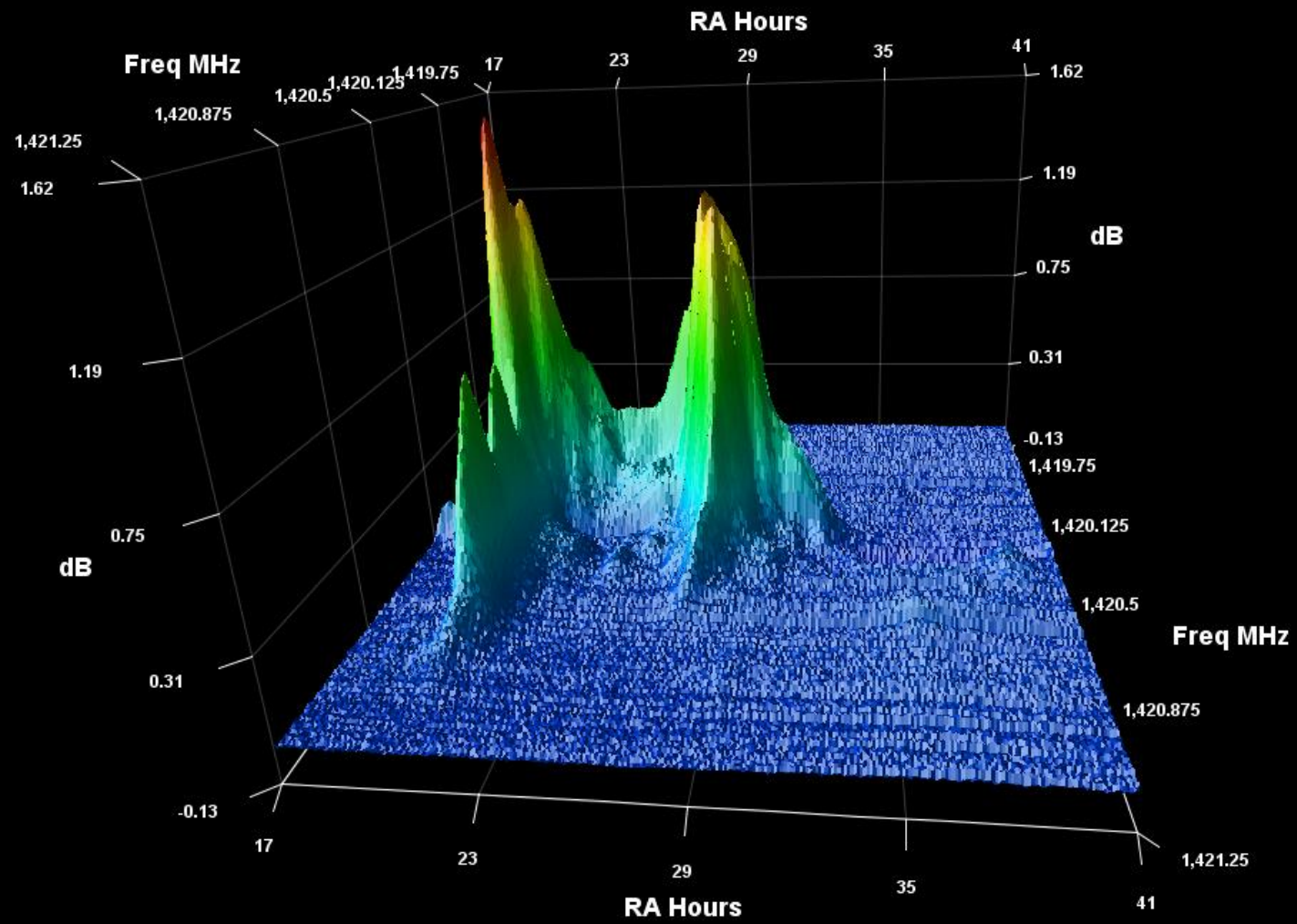
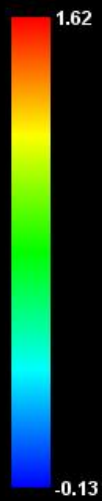

Radio Telescope beam at 47.5 degrees

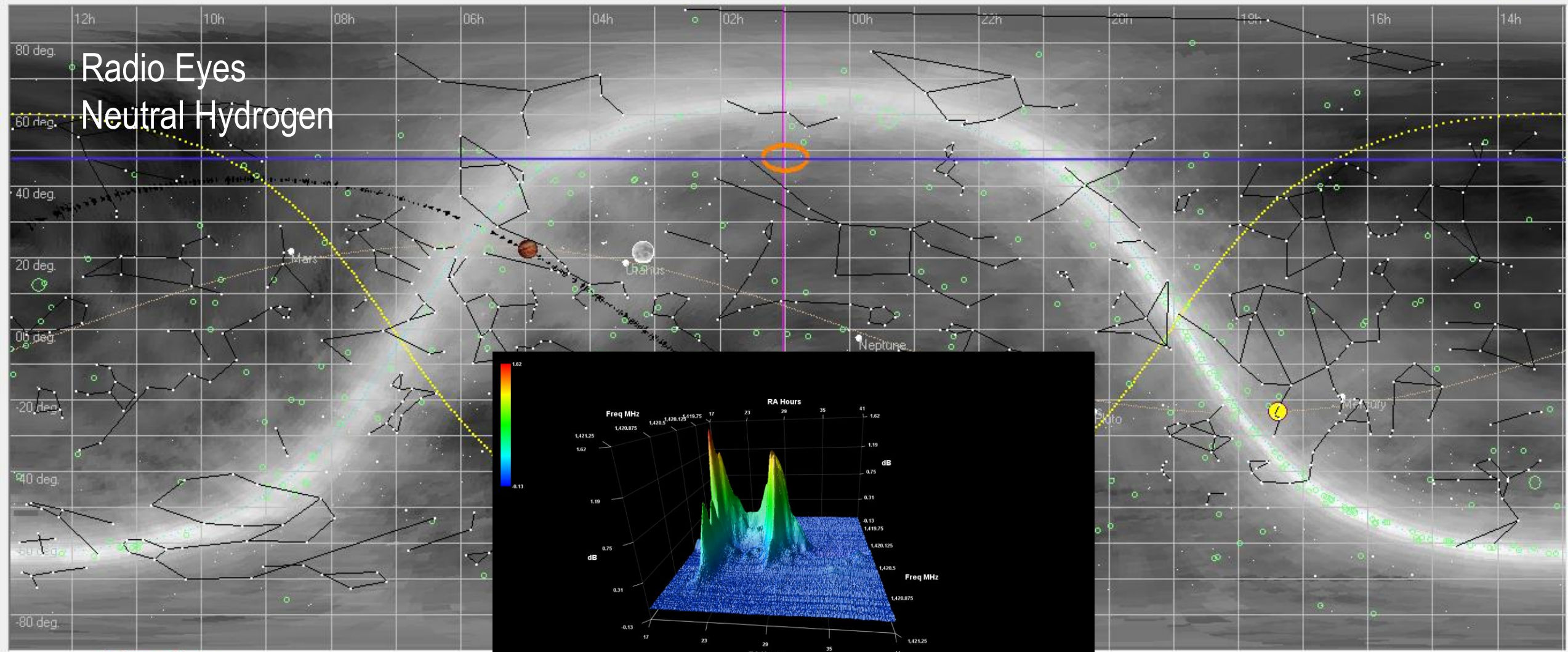

Radio Eyes
Neutral Hydrogen

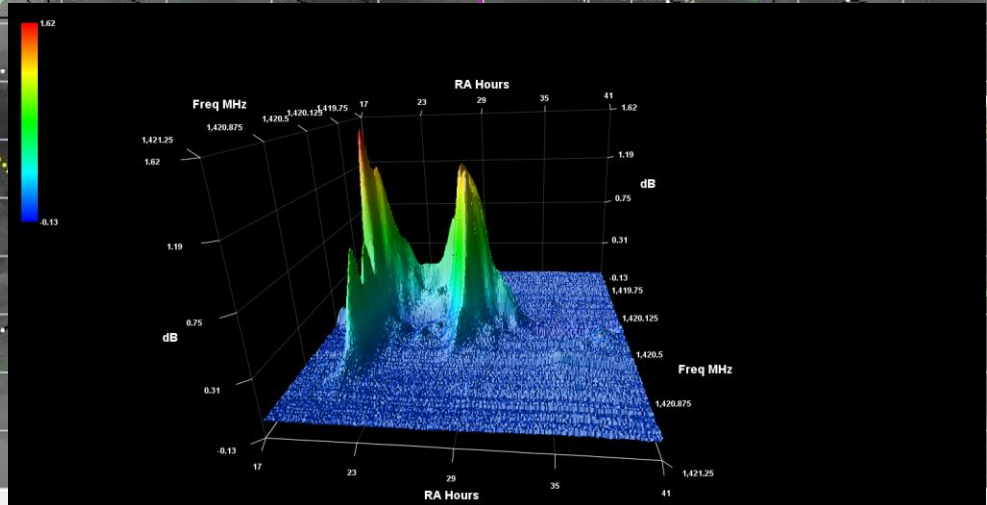

Reference - Beam				
RA	Declination	Elevation	Azimuth	LMST
00:59:38	47:59:11	71:36:35	358:34:11	01:02:20

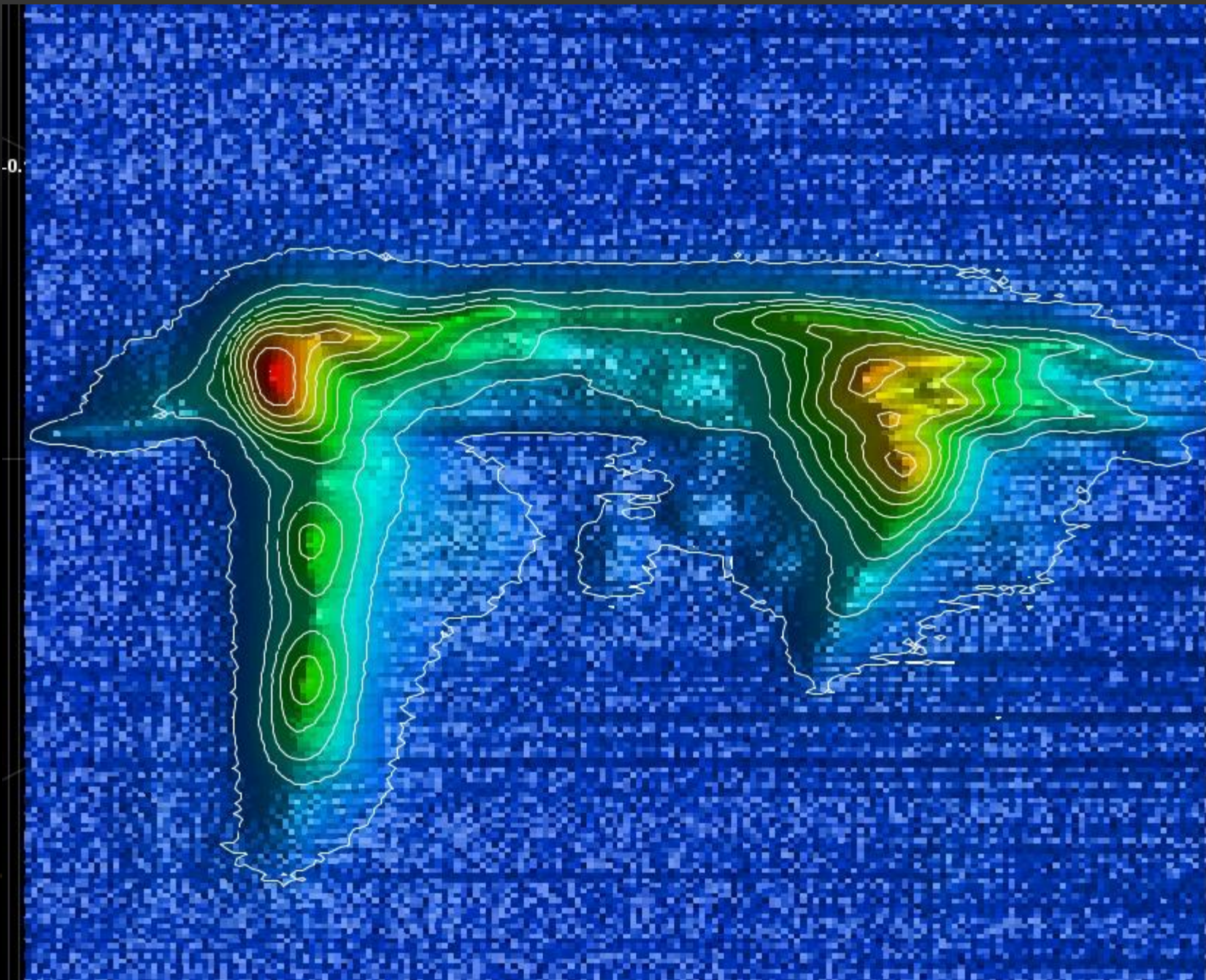

-0.

Contour
Plot

Produced by
Alex Pettit

Project 3 – Total Power Measurements with 2.1m Antenna

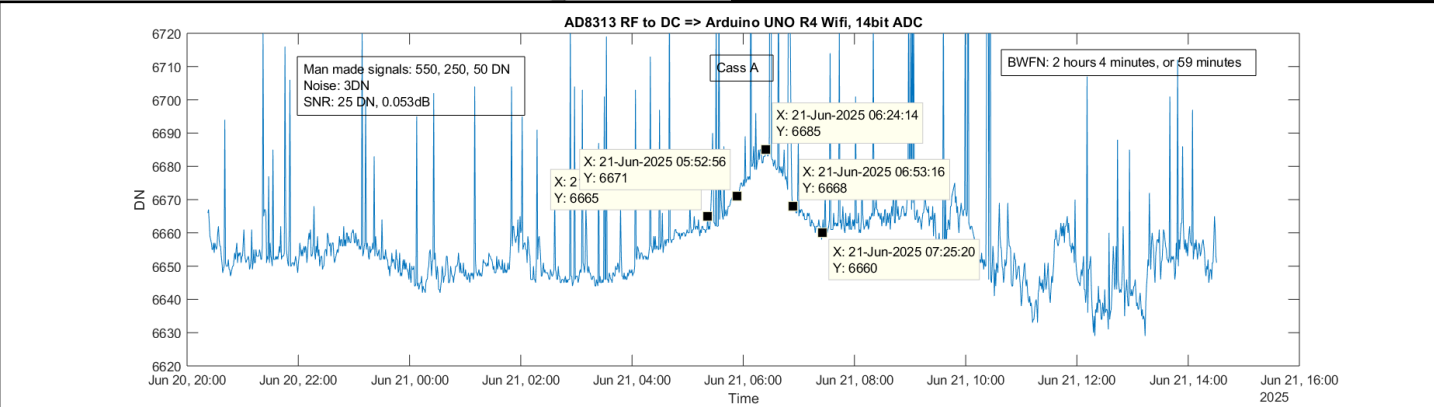
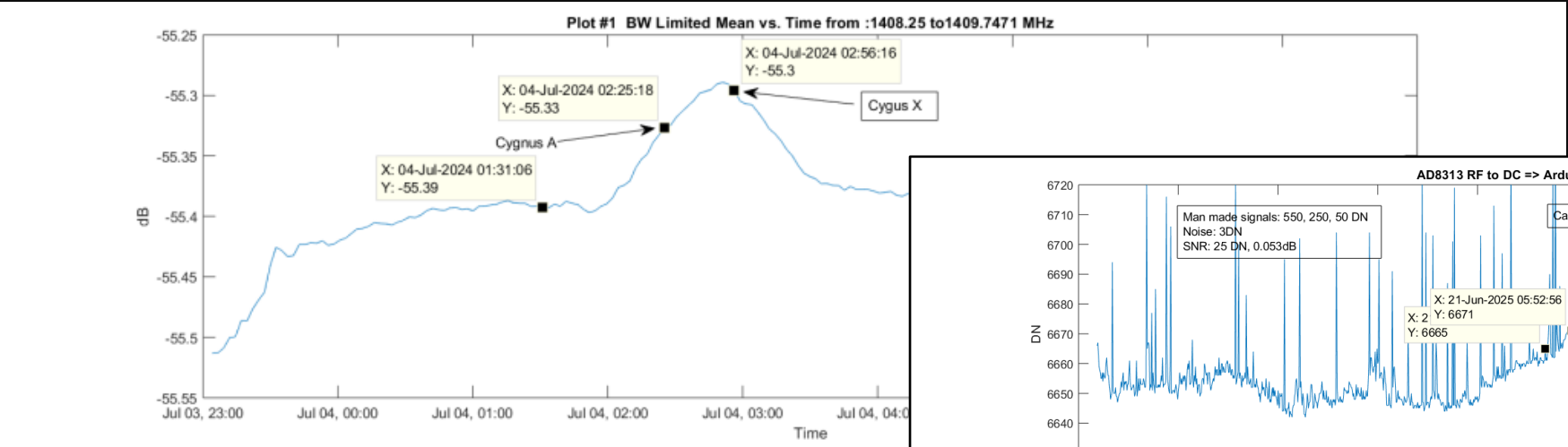
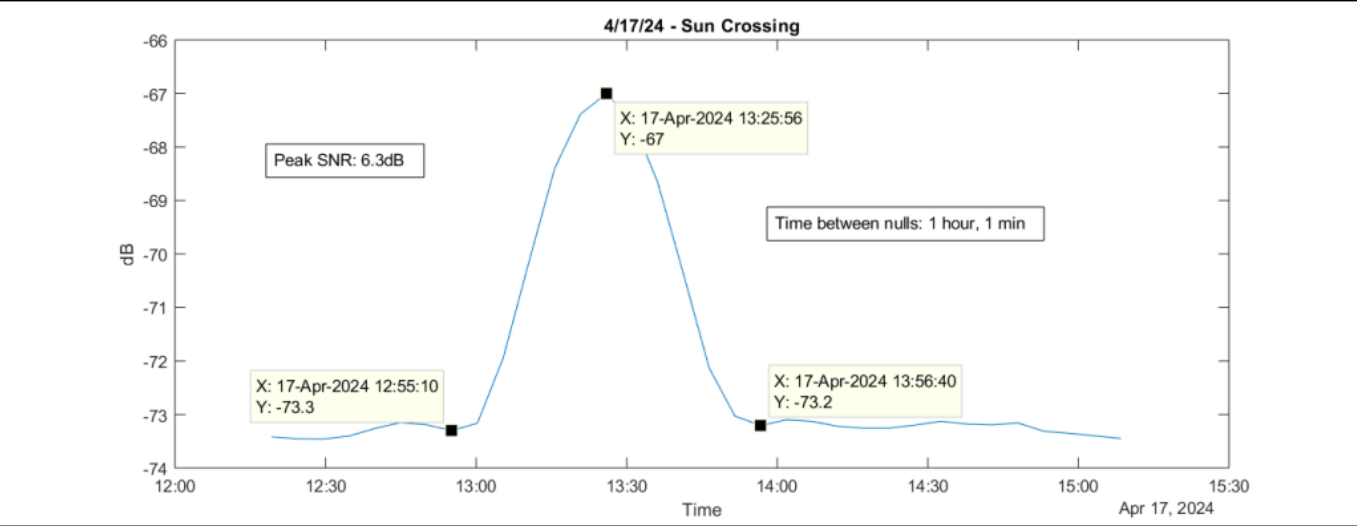
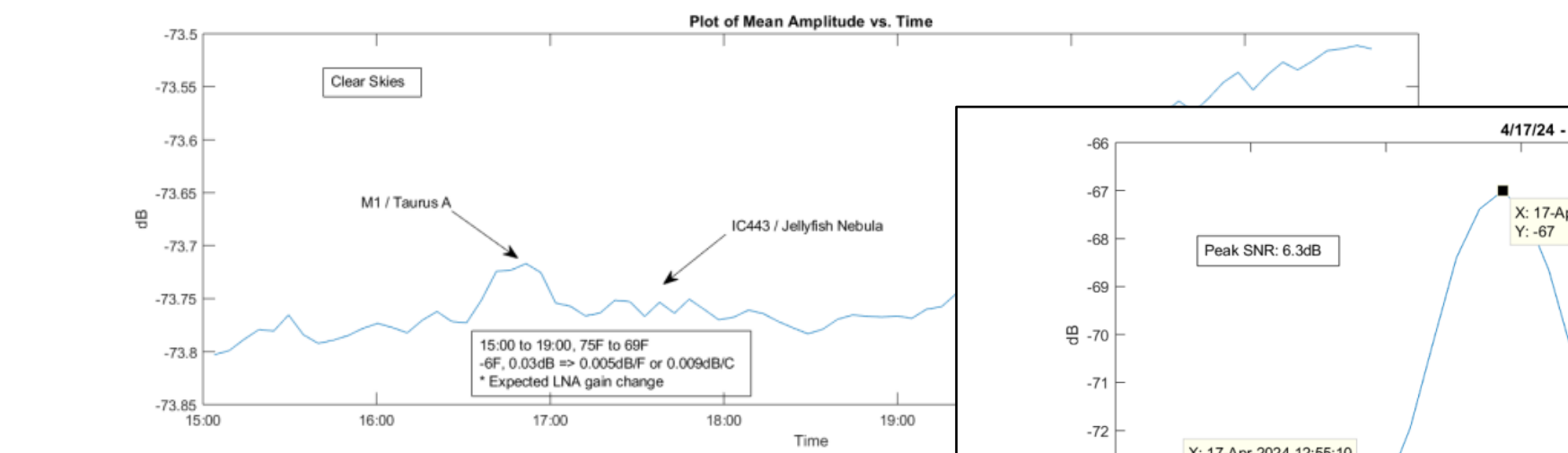

Project 3 – Total Power Measurements with 2.1m Antenna (cont'd)

➤ What is a Total Power Measurement?

- ❑ Previous measurements were spectrums: Frequency vs. Amplitude
- ❑ Total Power: Time vs. Amplitude => Total power contained in entire bandwidth detected plotted over time (hours, minutes)

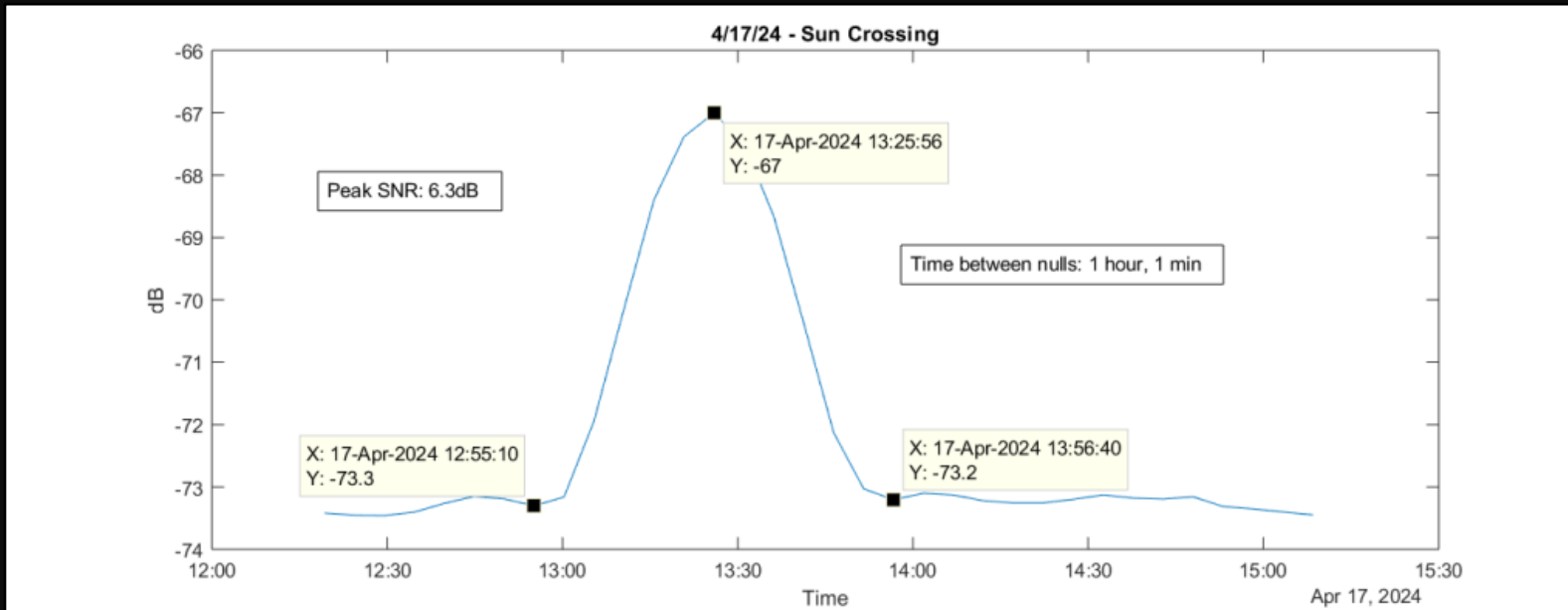

Bandwidth of Software Defined Radio (SDR) can be set. Max = 4.8MHz

Example – Sun Crossing: signal received as Sun crosses over radio telescope beam

Project 3 – Total Power Measurements with 2.1m Antenna (cont'd)

Project 3A

Sun Crossings and the Solar Flux Unit SFU

Project 3 – Total Power Measurements with 2.1m Antenna (cont'd)

- We can perform Sun crossings to measure the changing solar flux from day to day and over the solar cycle
- NOAA website lists the Sun's Solar Flux Unit (SFU) for each day for various frequencies:

https://services.swpc.noaa.gov/text/solar_radio_flux.txt

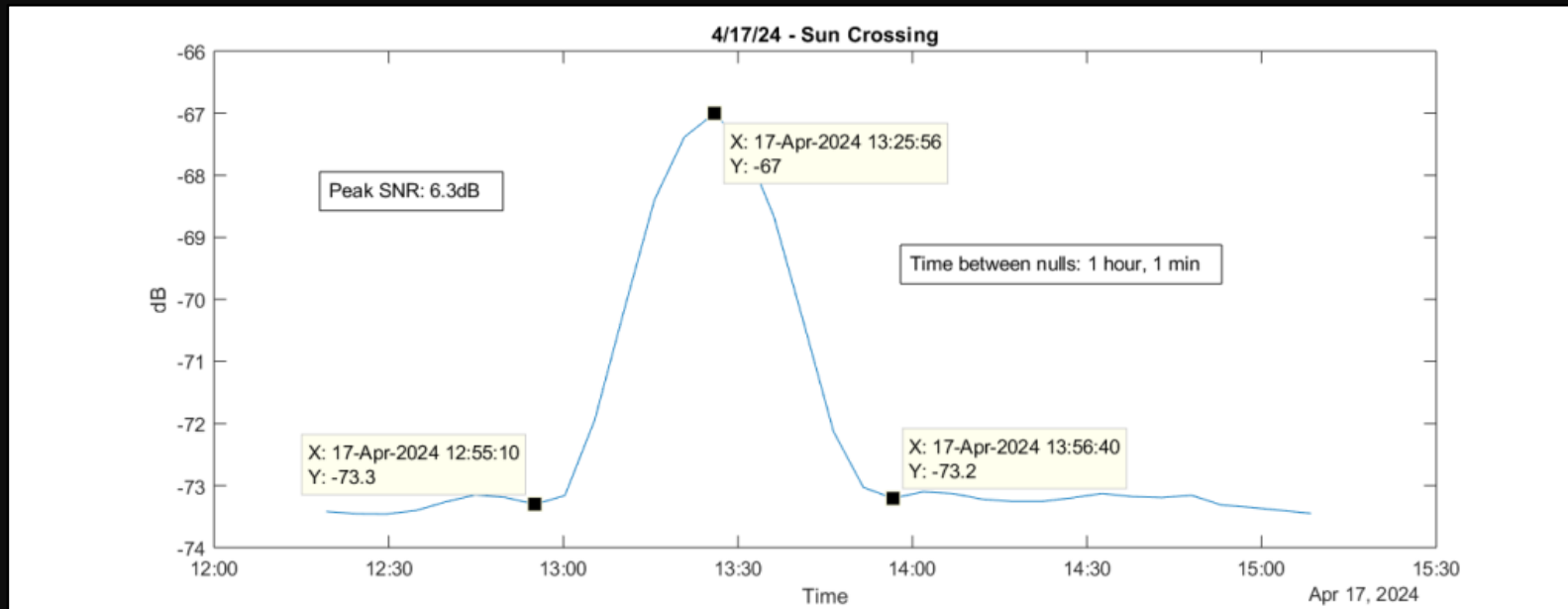

Doug Holland

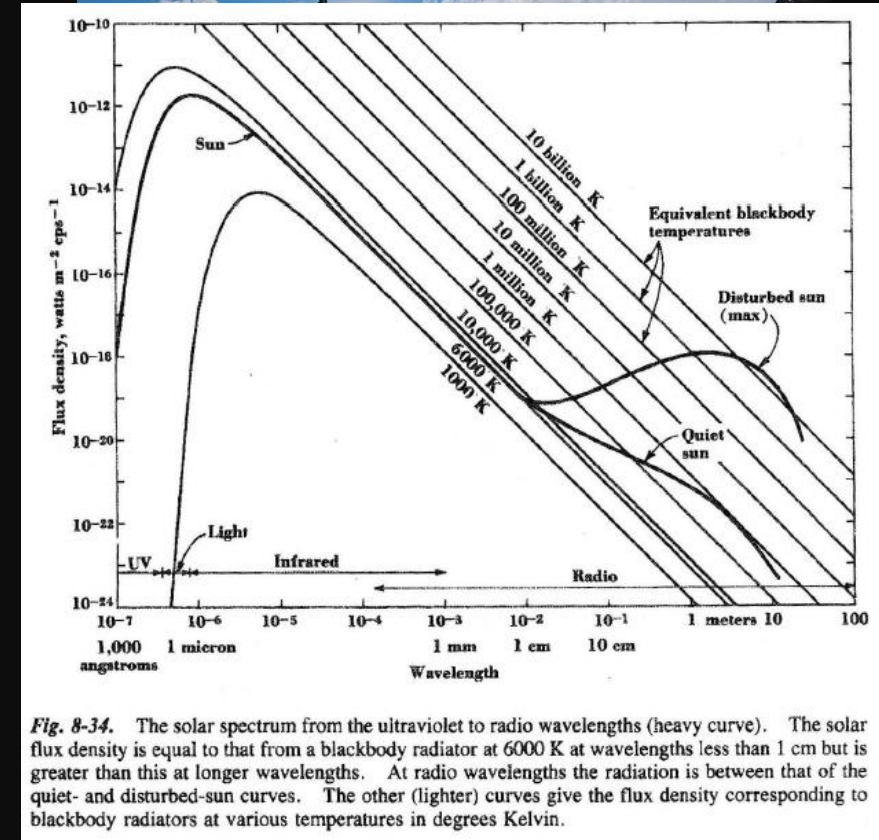

Radio Astronomy by John D. Kraus

Project 3 – Total Power Measurements with 2.1m Antenna (cont'd)

★ Project 3B

Total Power Measurements of Celestial Objects

Project 3 – Total Power Measurements with 2.1m Antenna (cont'd)

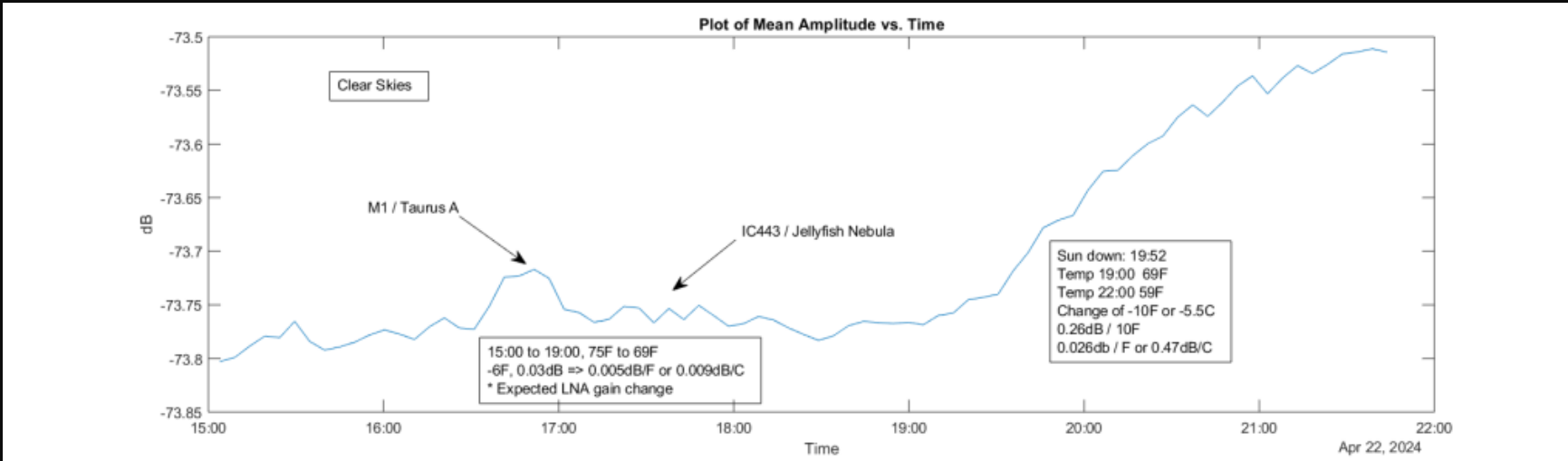

1407 MHz, 4.8MHz Bandwidth, 5 minute samples

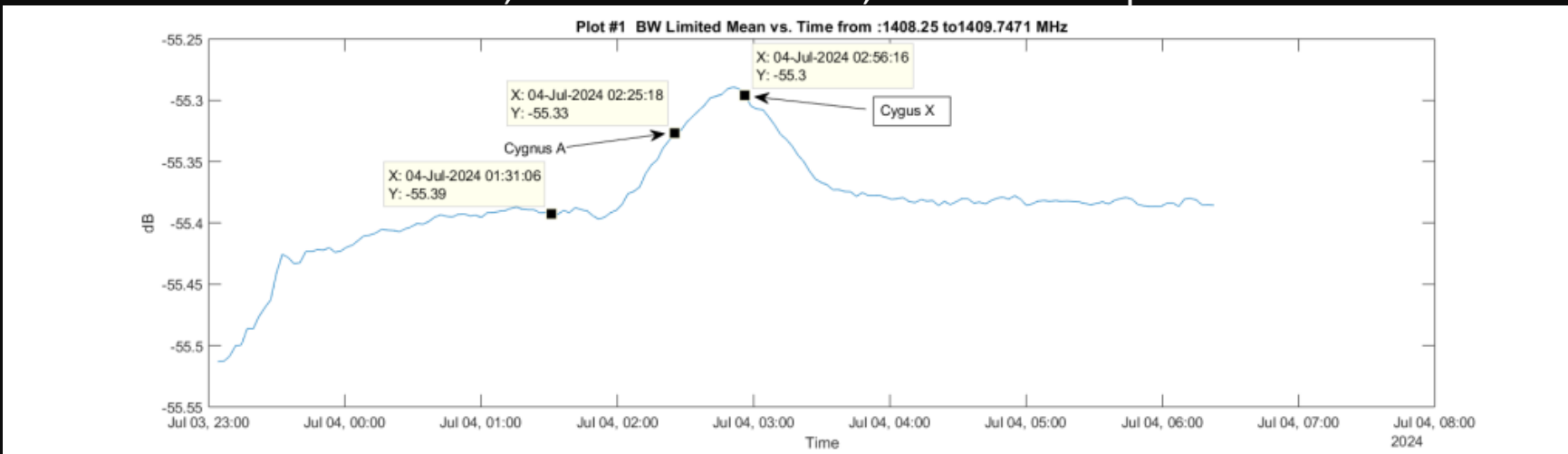

1409 MHz, 1.2MHz Bandwidth, 3 minute samples

2.1m Radio Telescope, H1 LNA, Airspy mini SDR, SDR# software

Doug Holland

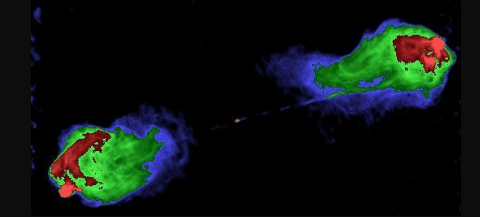

https://en.wikipedia.org/wiki/Cygnus_A#/media/File:3c405.jpg



[https://en.wikipedia.org/wiki/Cygnus_X_\(star_complex\)](https://en.wikipedia.org/wiki/Cygnus_X_(star_complex))

Project 3 – Total Power Measurements with 2.1m Antenna (cont'd)

Project 3C

Total Power Measurements using Power Detector Receiver

Project 3 – Total Power Measurements with 2.1m Antenna (cont'd)

We would like to increase the sensitivity of our radio telescope without having to make it bigger, and bigger

$$F_{\nu}(\text{min}) = \text{SNR} \left(\frac{4k T_{\text{sys}}}{A_{\text{eff}} \sqrt{bw * nt}} \right)$$

Sensitivity Formula

As \sqrt{bw} increases, minimum flux decreases

Increasing bw improves radio telescope sensitivity

$F_{\nu}(\text{min})$ = *minimum flux density*

T_{sys} = *system noise*

bw = *bandwidth*

n = *number of subsamples*

t = *sampling time*

SNR = *signal to noise ratio*

$4k$ = *4 x Boltzmann's constant*

Reflector
Gather & Focus
Electromagnetic Radiation

Feed Antenna
Transform free space
wave to guided wave
to electric current

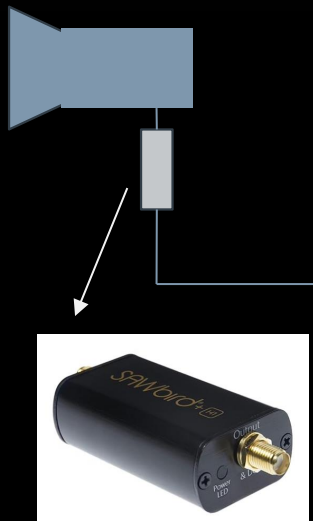

Low loss cable



AD8313

Low Noise Amplifier (LNA) +
Bandpass Filter (BPF)

Note – 65MHz Bandwidth

+



Arduino UNO R4 Wifi

Receiver:
Power Detector + Arduino
Full LNA 65MHz Bandwidth

SDR limited to 4.8MHz

WiFi



Computer gathering, storing,
processing & displaying radio
telescope signal

*Note – schematic of Power Detector receiver on web page
www.holland-observatory.net

Power Detector for Receiver

Project 3 – Total Power Measurements with 2.1m Antenna (cont'd)

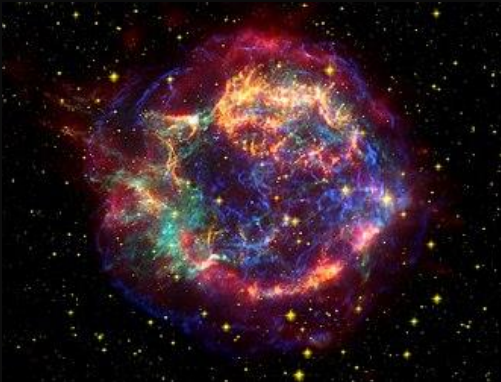
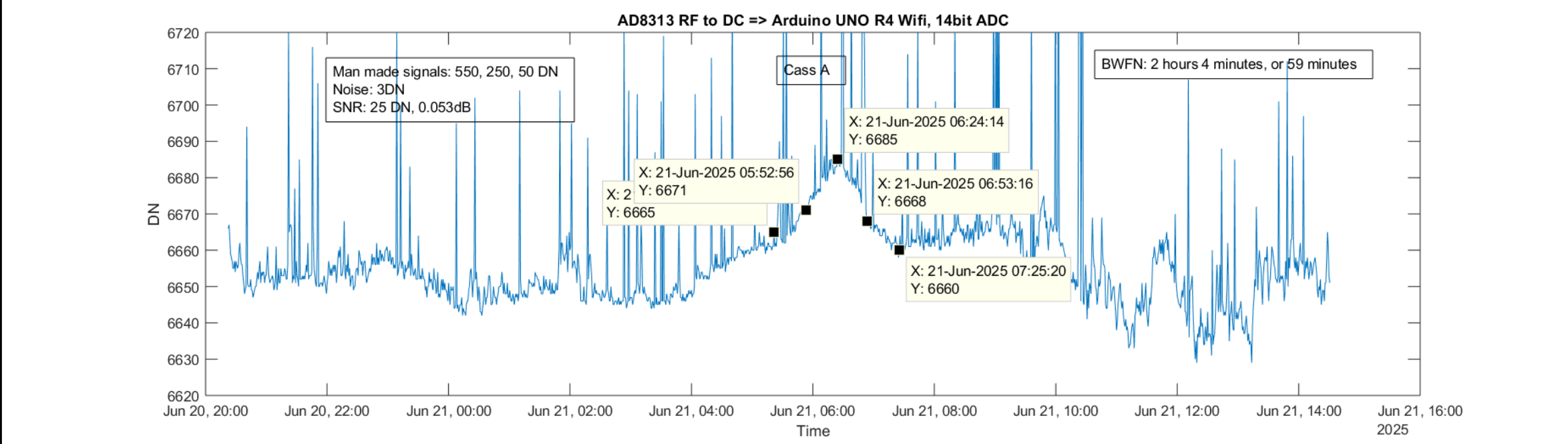

Increasing bandwidth (bw) improves sensitivity,
but lets more man-made noise through

https://en.wikipedia.org/wiki/Cassiopeia_A

Project 4 – What Can be Accomplished with a Satellite TV Dish Antenna

Member of our astronomy club asked –
Can a satellite TV dish be used for radio astronomy?

Rule of thumb – When someone tells you
something cannot be done, someone else is
probably already doing it -



SARA – the Society of Amateur Radio Astronomers

Under projects

The itty bitty radio telescope



=> Another member asked about measuring the temperature of the Moon <=

Measuring the Temperature of the Moon

★ Project 4



WE WILL ATTEMPT TO USE A SATELLITE TV
DISH ANTENNA TO MEASURE THE
TEMPERATURE OF THE MOON



First question – Can a satellite dish be used to detect celestial objects?

How about try something really bright, like the **Sun**



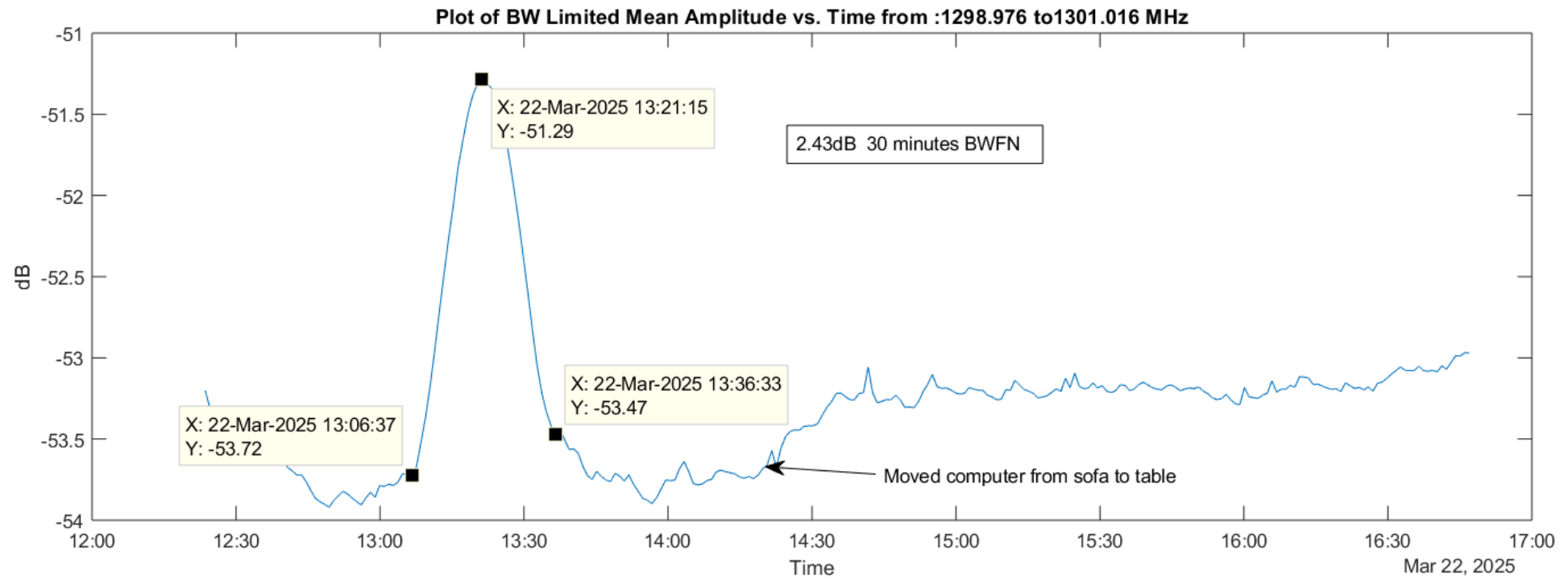

Answer – YES! A satellite dish can detect the Sun!

One challenge -

Date of measurement 3/22. **Spring Equinox** was 3/20.

Anyone got an idea why this could cause a problem?

Second question – Is there any chance a satellite dish could detect the Moon?

1. What frequencies do these detect?

- From Internet search: 12.2 to 12.7GHz

2. Can we detect the Moon at these frequencies?

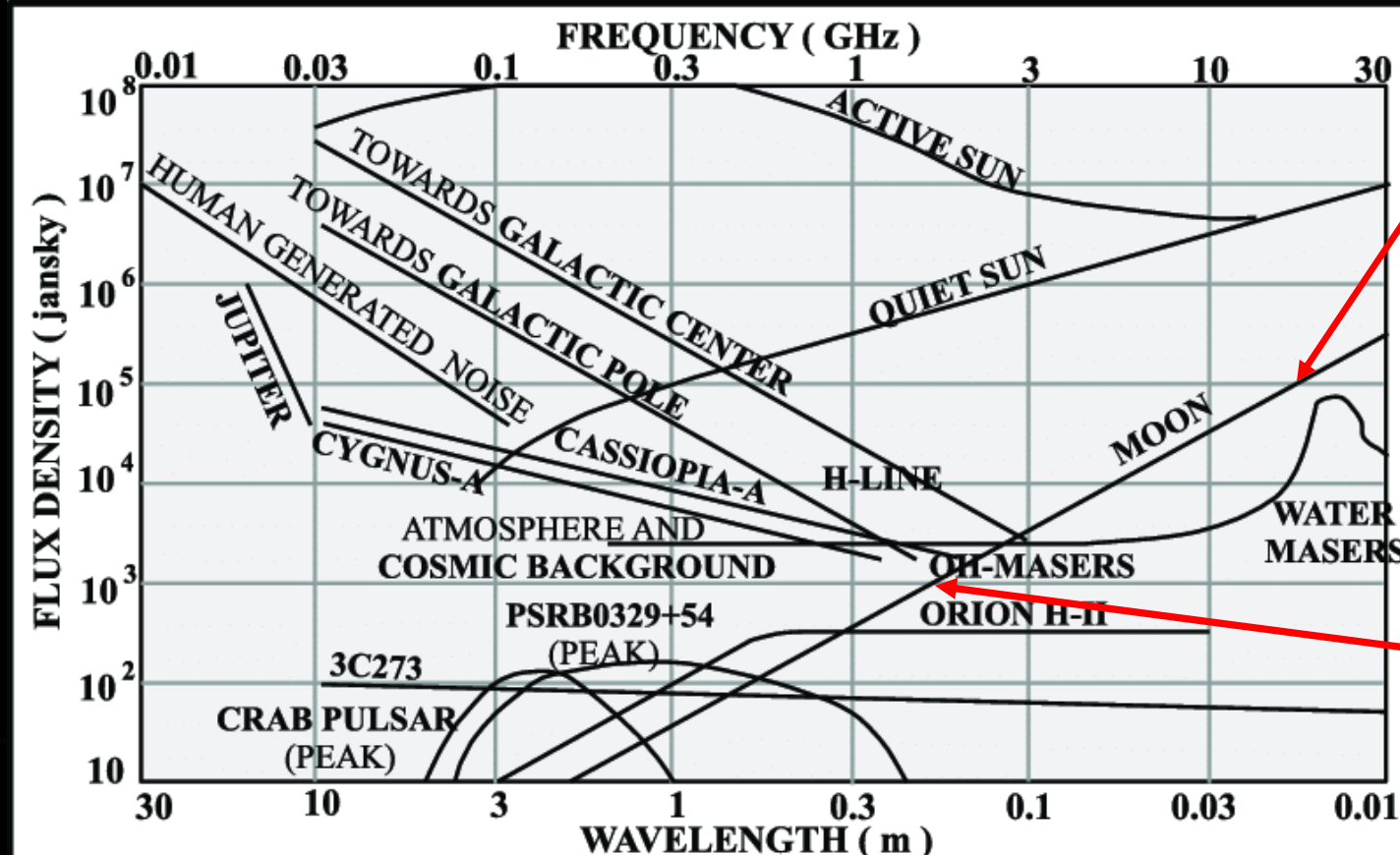

Approx. 2.36cm (12.7GHz)

!! Moon is about 100x brighter at 12.7GHz than 1.4GHz !!

Approx. 21cm (1.4GHz)
Previous frequency area

Third question – Can we use a Software Defined Radio (SDR) for our receiver?

- Freq range of RTL-SDR: 500KHz to 1766MHz
- Freq range of Airspy Mini: 24 to 1700MHz



Signal 12GHz

Low Noise Block (LNB)

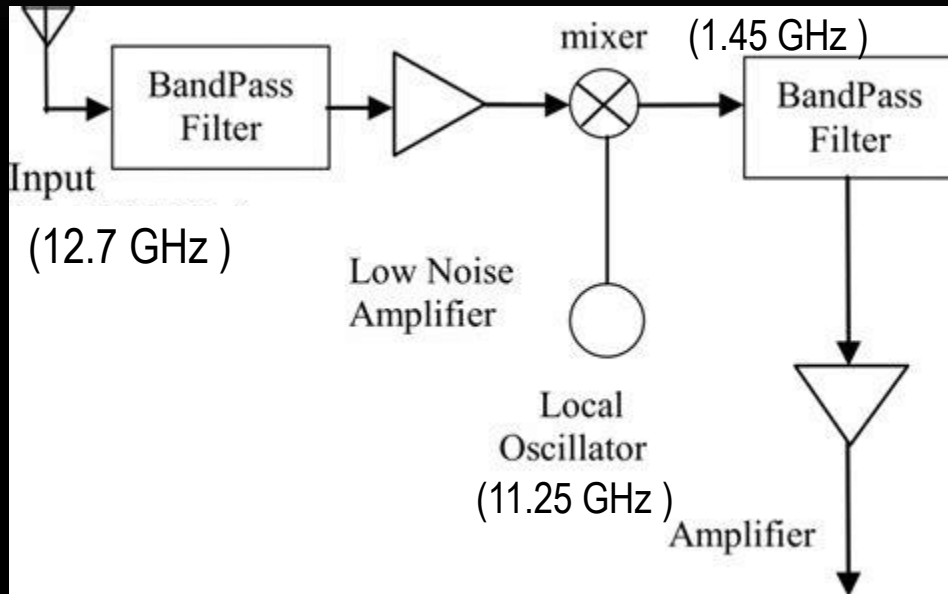

wiringdigital.com

$12.7\text{GHz} - 11.25\text{GHz} = 1.45\text{GHz} (1450\text{MHz}) \Rightarrow$ within range of SDR \Rightarrow YES !!

Fourth question – How do you power the LNB (12V) without blowing up SDR?

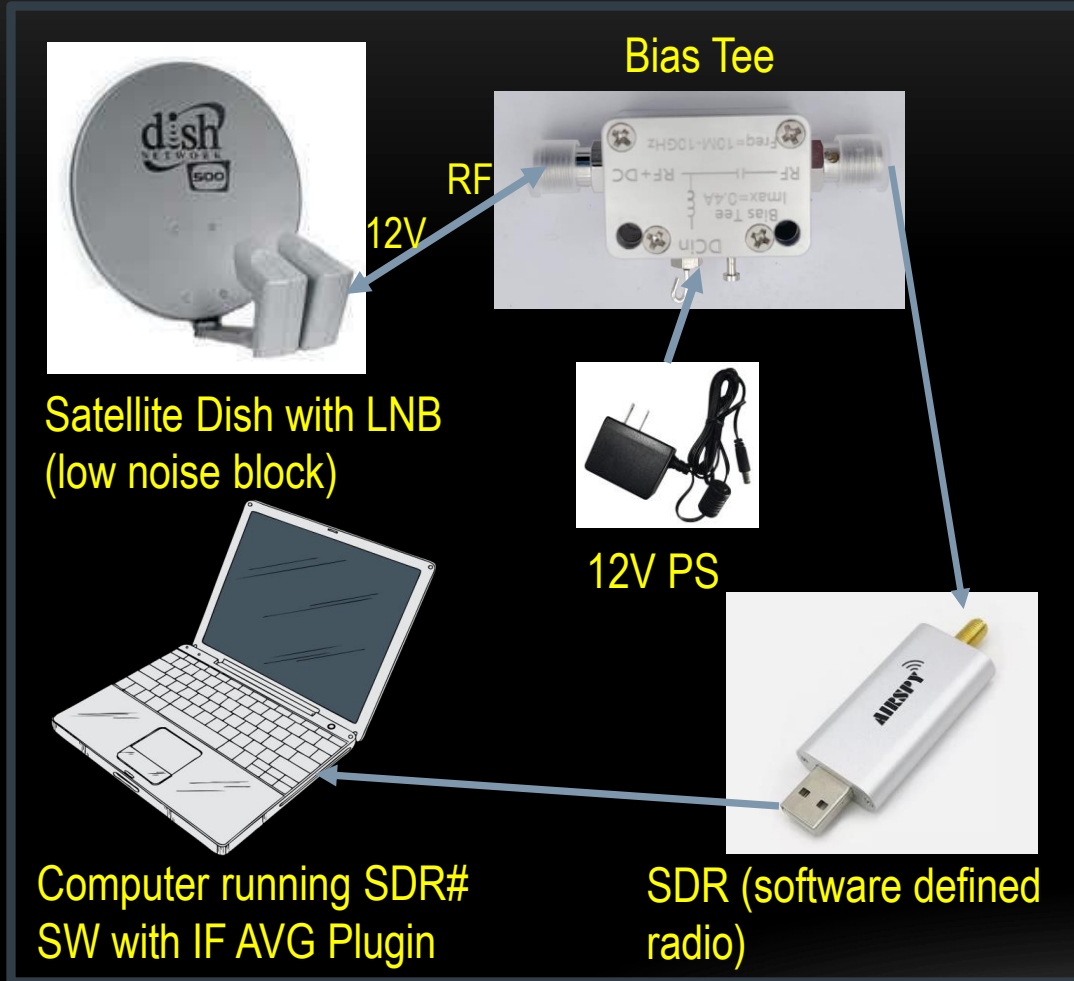

Aliexpress: Bias Tee / DC Block – routes power to LNB but not to SDR

Computer running
SDR# with IF Average Plugin

Pepper Plant

Airspy Mini SDR

SDR Cooling System
Not Required

Bias Tee

Cable going to
dish antenna

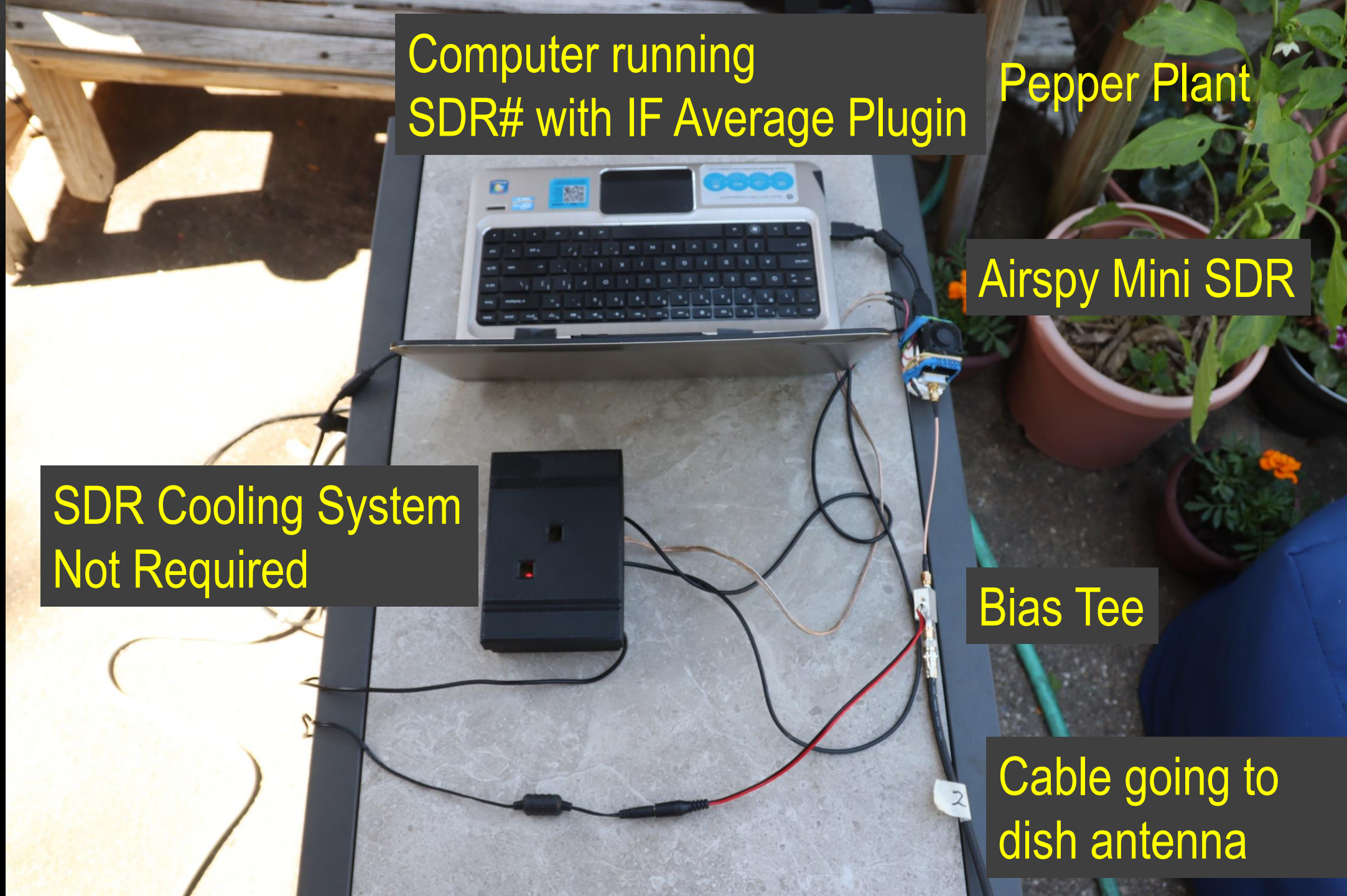

Fifth question – How do you know where antenna is pointing?

- Shape is a section of a parabola, offset feed antenna (LNB)



- *There is a plate on the bottom*

??? Any chance that the angle of the plate corresponds with direction of the antenna beam ???

!!! Turns out that it does => meaning that a protractor with weight on string can be used to set Declination !!!

=> Use compass to align antenna North / South along local meridian

Making the Measurement, Requirements

- Need to determine location of Moon
 - DEC changes every day
 - Find for that day's transit (when it crosses over local meridian – the line in the sky, overhead from North to South)
 - Use Planetarium Software: Kstars, The Sky, Stellarium, etc.
- Need to find usable frequency
 - Satellite interference experienced from 12.45 to 12.65GHz
 - Used 12.7GHz (1450MHz SDR) for measurement



Moon Temperature Measuring Configuration
(with cat)

Using the Moon's Declination (at transit) to Set Protractor

Local Latitude – Moon's DEC = Protractor Setting

Example:

$$29^{\circ} 36' - 04^{\circ} 24' = 25^{\circ} 12'$$

=> Set protractor $25^{\circ} 12'$
South of straight up

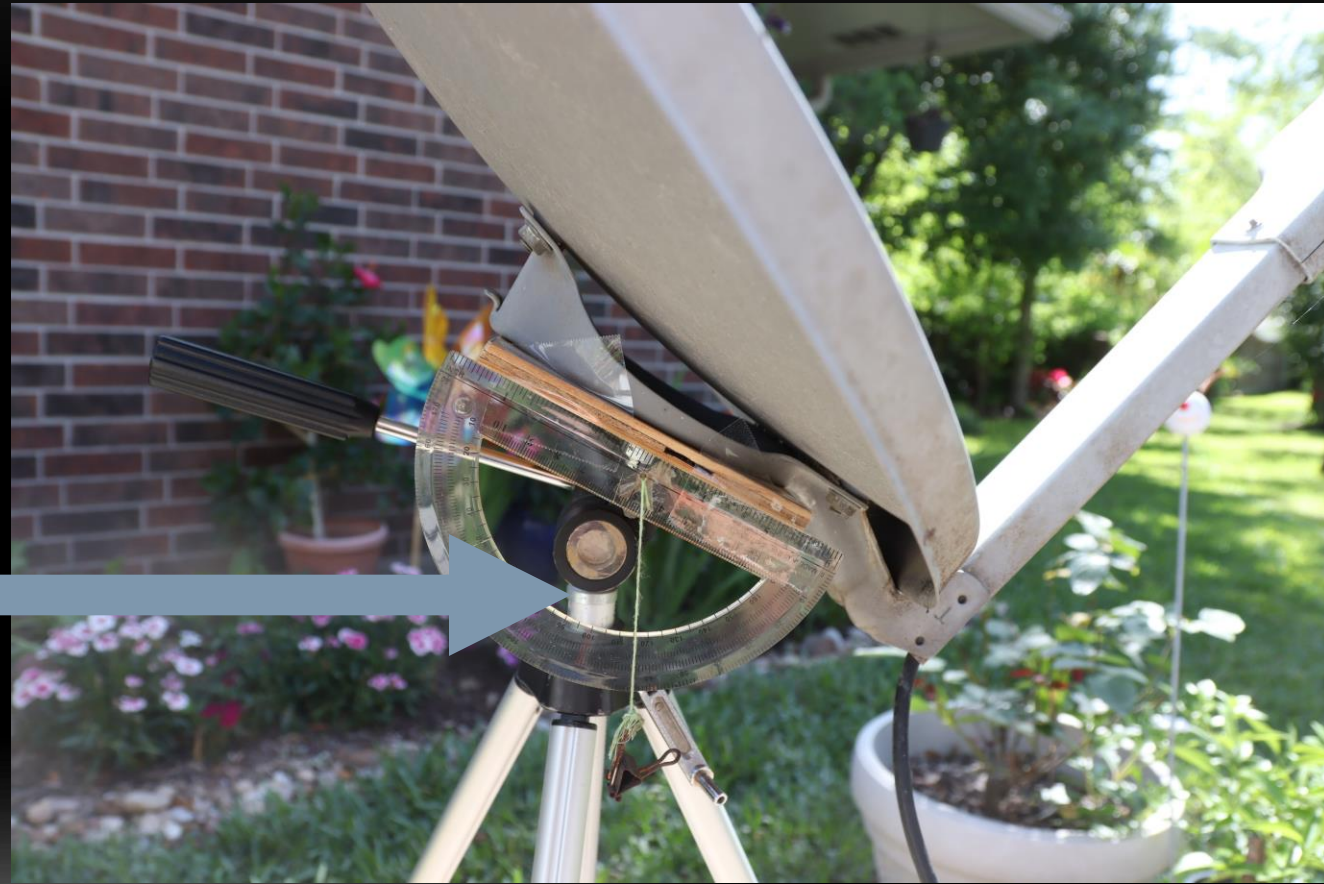

Making the Measurement, Software

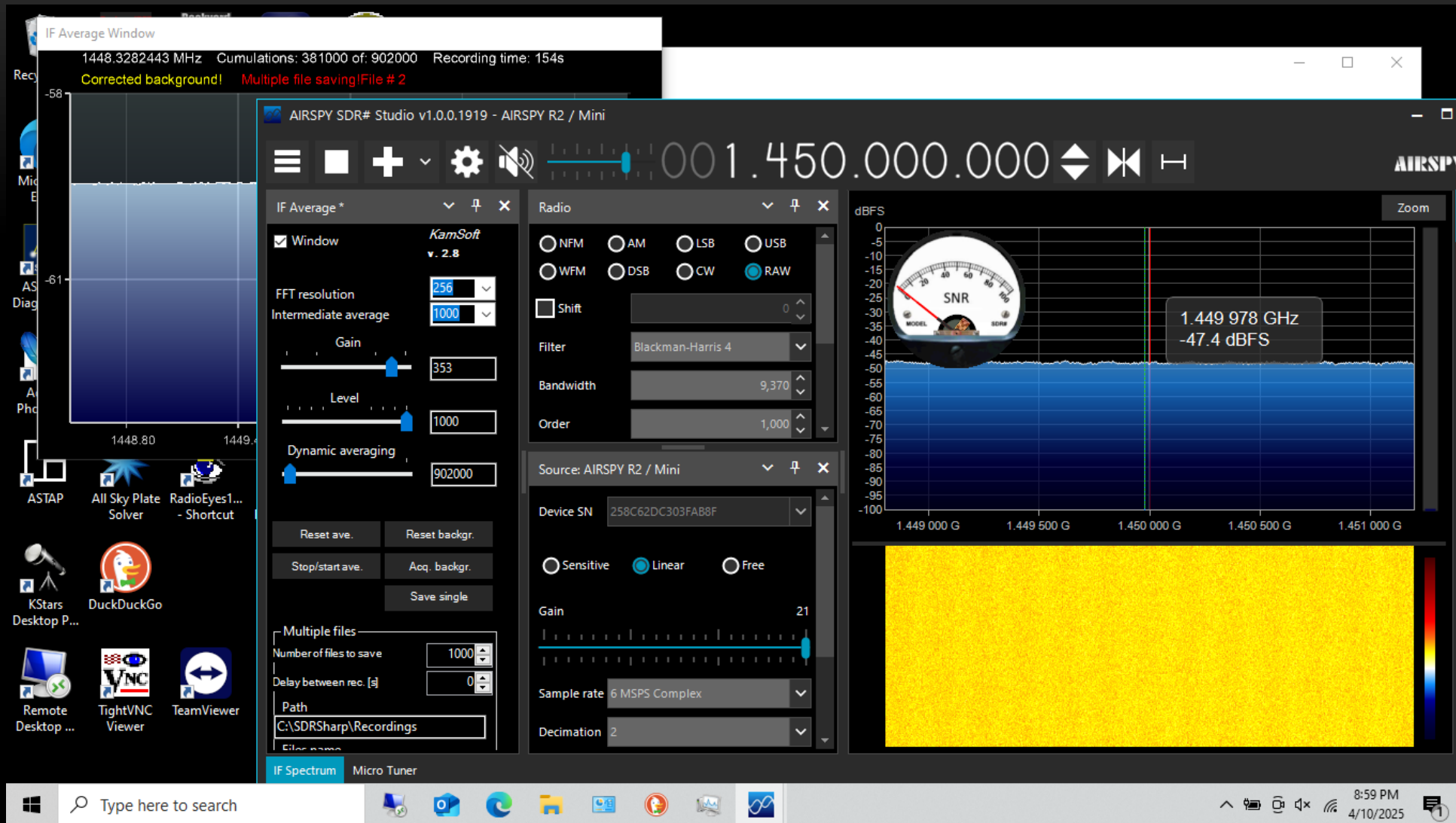

SDR# with IF Average Plugin (free) – IF Average Plugin creates data files that can be plotted in other program (Excel, Matlab, etc.; example uses Matlab)

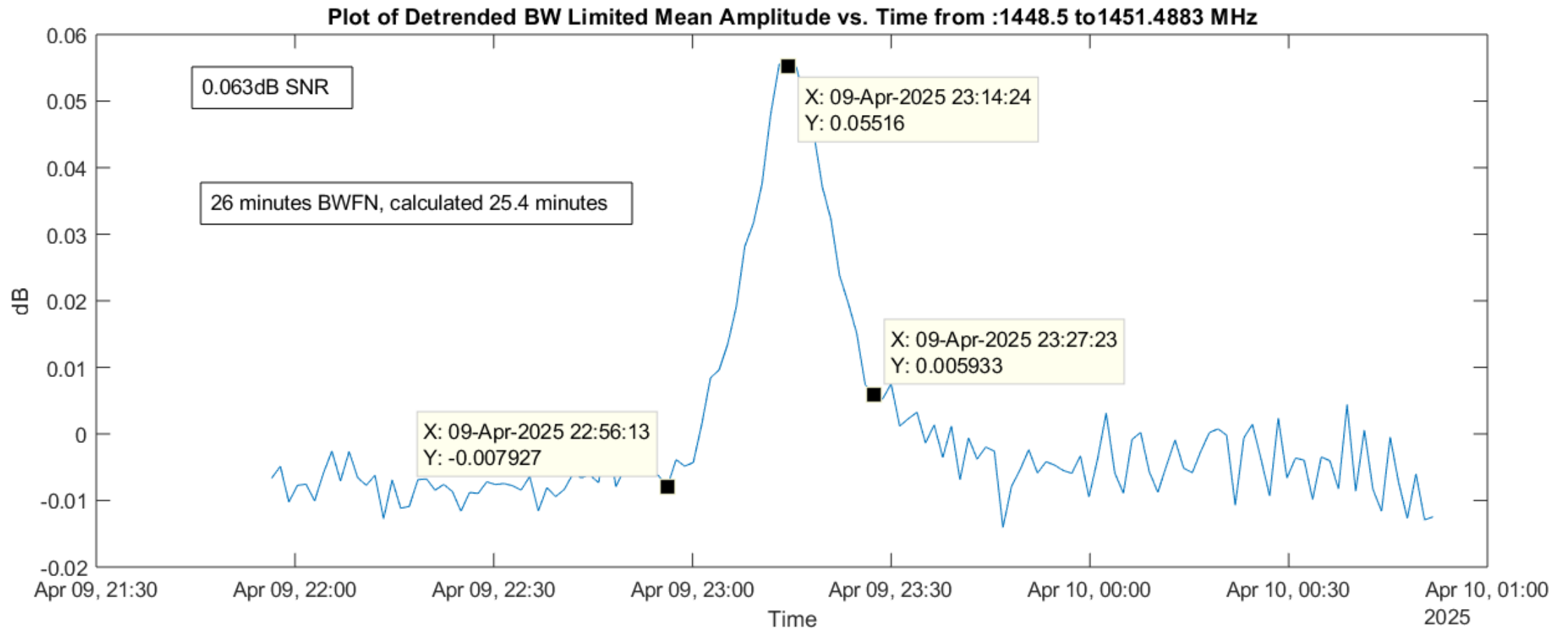

Moon Measurement – Amplitude vs. Time

How to use measurement to determine temperature of the Moon



Math is Fun !!

$$T_{moon} = \frac{T_{eff}}{R}$$

Antenna Beam
HPBW 3.17°

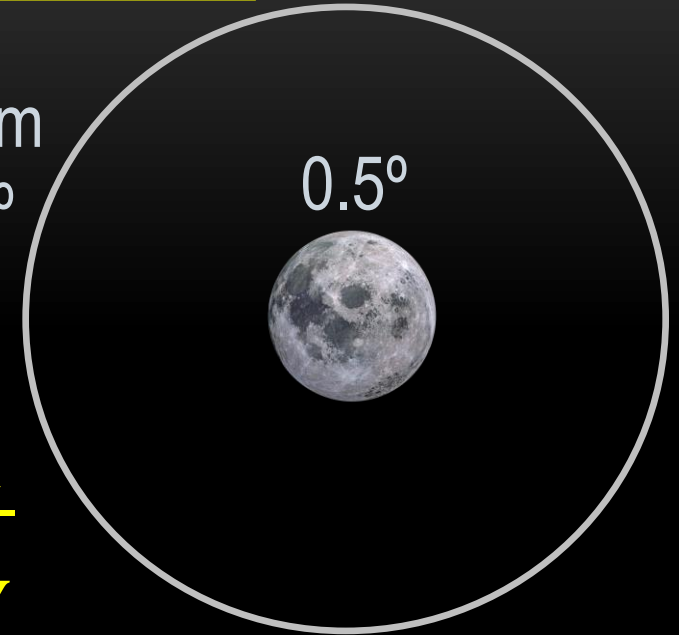

$$R = \frac{\text{Moon (solid angle)}}{\text{Antenna HPBW (solid angle)}} = \frac{\pi r_{Moon}^2}{\pi r_{HPBW}^2}$$

$$R = \frac{\pi \cdot (0.25^\circ)^2}{\pi \cdot (1.59^\circ)^2} = 0.0247$$

From SARA instruction videos
HPBW (half power beam width)

$$HPBW = 70^\circ \frac{\lambda}{D}$$

λ = wavelength, D = diameter

$$HPBW = 70^\circ \frac{0.0236m}{0.5207m} = 3.17^\circ$$

$$T_{eff} = T_{total} - T_{sys}$$

T_{sys} = system noise level

$$T_{sys} = \frac{T_h - yT_c}{y - 1}$$

T_h = temperature of hot area, garage wall (82°F)

T_c = temperature of cold area, sky (10K)

Need T_h in Kelvin, K

$$(((82^{\circ}F - 32^{\circ}F) \frac{5}{9}) + 273.15K) = 300.9K$$

$$T_{sys} = \frac{300.9K - 2.0893(10K)}{2.0893 - 1}$$

$$T_{sys} = 257K$$



$$P_{wrhotdB} - P_{wrcolddb} = 10 \log(y)$$

$P_{wrhotdB}$ = Hot power measured in dB

$P_{wrcolddb}$ = Cold power measured in dB

$$-47.5dB - (-50.7dB) = 3.2dB = 10 \log(y)$$

$$y = 2.0893$$

$$T_{eff} = T_{total} - T_{sys}$$

$$\frac{T_{total}}{T_{sys}} = 10^{\Delta T_{db}/10}$$

$$\Delta T_{db} = \text{MoondB above cold sky} = 0.063\text{dB}$$

$$\frac{T_{total}}{T_{sys}} = 10^{0.063\text{db}/10} = 1.0146$$

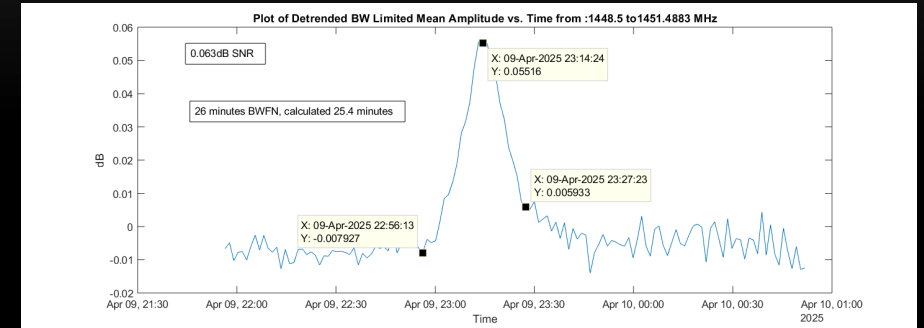

$$T_{total} = T_{sys} \cdot 1.0146 = 257\text{K} \cdot 1.0146 = 260.75\text{K}$$

$$T_{eff} = T_{total} - T_{sys} = 260.75\text{K} - 257\text{K} = 3.75\text{K}$$

$$T_{moon} = \frac{T_{eff}}{R} = \frac{3.75\text{K}}{0.0247} = 151.8\text{K}$$

Measured temperature of the Moon: 151.8K

Expected temperature, a little above 200K?

Changes with phase of the Moon

Data taken about half way between first quarter and full Moon

The Radio Sky, Spectra, the Solar System and Our Galaxy

8-55

Wavelength = 2.36cm

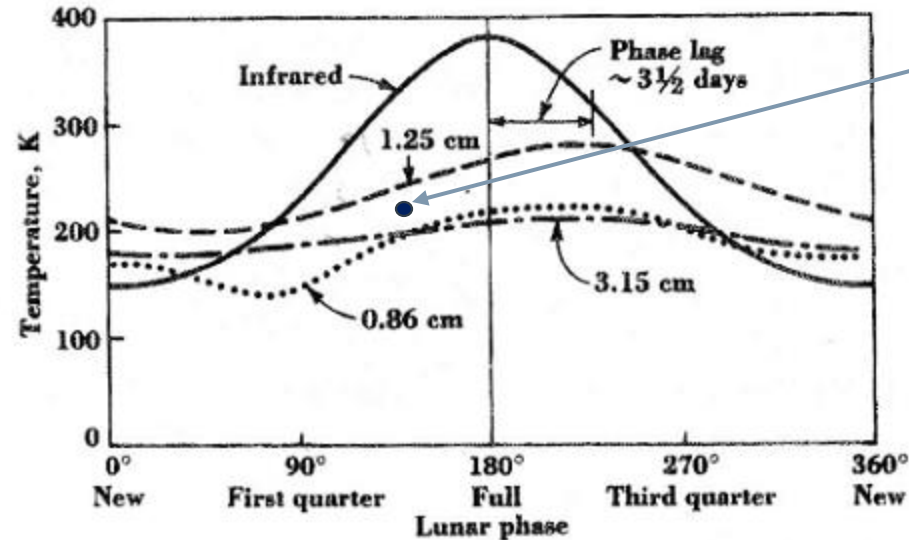
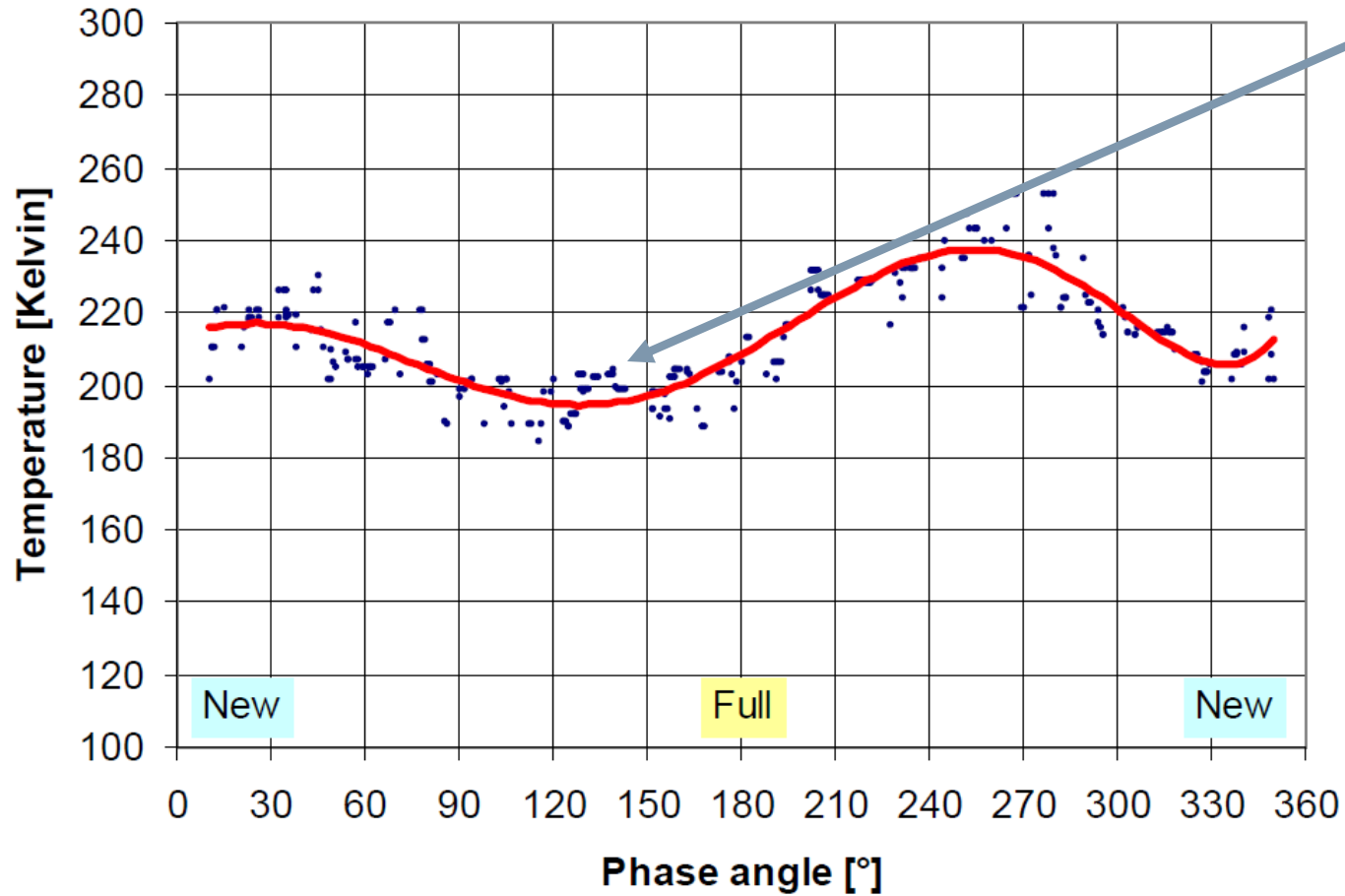

Fig. 8-41. Lunar temperature in kelvins as a function of lunar phase, showing the temperature variation, at infrared wavelengths and at wavelengths of 0.86, 1.25, and 3.15 cm. The temperatures are those of an equivalent blackbody radiator.

Radio Astronomy
by John D. Kraus

“The smaller temperature range of the radio temperatures as compared to the infrared values is taken to indicate that the microwave radiation originates at some depth below the surface of the Moon, whereas the infrared radiation comes from a thin surface layer.”

Moon Surface Temperature @ 2.77cm



Actual measurements just above 200K

Another reference at approx. same wavelength: 2.77cm vs. 2.36cm

Where could there be errors in our method or calculation?

What about if we measure HPBW rather than calculate it?

15min/60min x
15°/hour = 3.75°

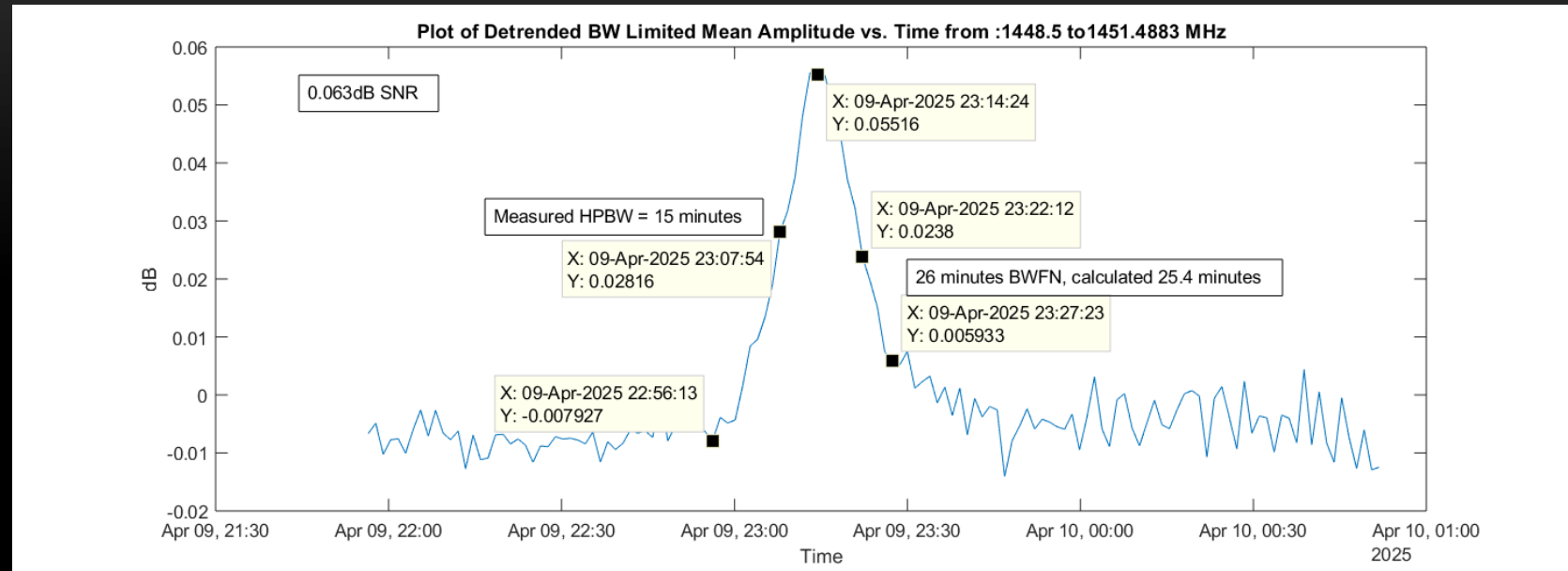

$$R = \frac{\pi \cdot (0.25^\circ)^2}{\pi \cdot (1.875^\circ)^2} = 0.0178$$

$$T_{moon} = \frac{T_{eff}}{R} = \frac{3.75K}{0.0178} = 210K$$

About expected value

Conclusion =>

1. A reasonably ok signal can be received from the Moon at 12.7GHz with a Satellite TV Dish antenna
2. The temperature of the Moon can be measured, with relaxed precision, if measured HPBW is used, and patience

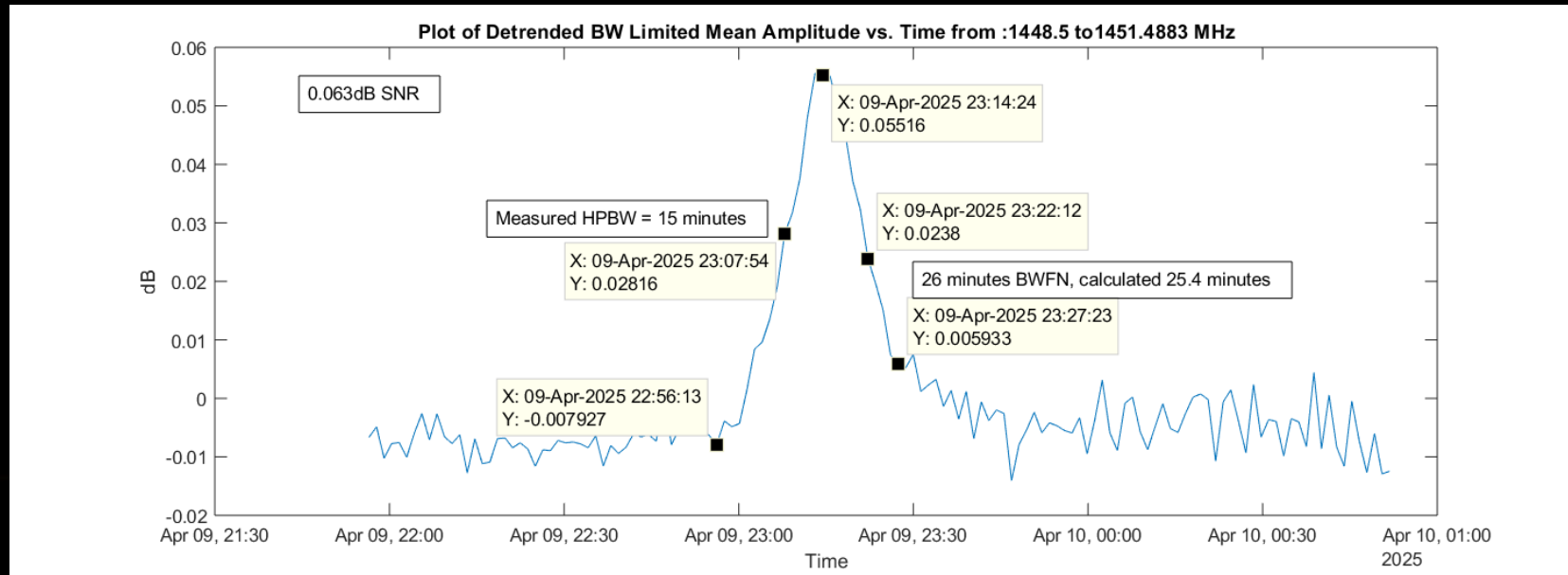

Other Projects that Can Be Done

- Measure rotation rate of our galaxy, the Milky Way
- Interferometer
- Detect meteors – Sudden Ionospheric Disturbances (SID)
- Detect solar flares – Sudden Ionospheric Disturbance (SID)
- Receive radio signals from Jupiter – Radio Jove
- Detect Water Masers at 22GHz
- More...

Doug Holland

Resources Available for Amateur Radio Astronomy

- Radio Astronomy, 2nd Edition by John D. Kraus, 1986
- Fundamentals of Radio Astronomy, Observational Methods by Jonathan M. Marr, 2016
- Essential Radio Astronomy by James J. Condon and Scott M. Ransom
Online book, <https://www.cv.nrao.edu/~sransom/web/xxx.html>
- Society of Amateur Radio Astronomers (SARA), \$20 per year (well worth it) <https://www.radio-astronomy.org/>
- Facebook: Amateur Radio Astronomy (group), 6.3K members

www.holland-observatory.net